

Equipment Manual



Envirotronics 

How did we do?

Thank you for purchasing this Envirotronics chamber. While we feel we have made every effort to ensure that you are completely satisfied with our equipment, we would like to give you this opportunity to tell us how we did. Your observations, opinions, and suggestions are more than "important to us" - they are vital to our continual improvement. Please take a moment, answer the questions below and let us know how you feel about your experience with Envirotronics.

When you have finished, please return the form to us. You may fax it to us at (616) 554-5021, email it to us at quality@envirotronics.com, or return it to us through the mail at: Quality Department, Envirotronics, 3881 N. Greenbrooke SE, Grand Rapids, MI 49512, USA.

Thank you for helping us to serve you better.
Your Envirotronics Team

Date _____
Name _____ Position _____
Company _____
Location _____

Sales

	Yes	No
Did our salesperson seem knowledgeable?.....	<input type="checkbox"/>	<input type="checkbox"/>
Was our salesperson courteous and prompt in responding to your requests?.....	<input type="checkbox"/>	<input type="checkbox"/>
Did our salesperson advise you that we have a full service department, offer A2LA accredited calibrations, and preventive maintenance plans?.....	<input type="checkbox"/>	<input type="checkbox"/>
Did our salesperson explain our Value Plus Program to you?.....	<input type="checkbox"/>	<input type="checkbox"/>
Did our salesperson provide you with after-the-sale follow-up?.....	<input type="checkbox"/>	<input type="checkbox"/>
Did your experience with our salesperson... <input type="checkbox"/> exceed your expectations? <input type="checkbox"/> meet your expectations? <input type="checkbox"/> fall short of your expectations?		

Delivery

	Yes	No
Did you receive our equipment specifications and quotations when promised?.....	<input type="checkbox"/>	<input type="checkbox"/>
Did you feel our "lead time" was... <input type="checkbox"/> short <input type="checkbox"/> about what you expected <input type="checkbox"/> too long		
Was the equipment delivered when it was promised?.....	<input type="checkbox"/>	<input type="checkbox"/>
Do you feel the equipment was delivered in good condition?.....	<input type="checkbox"/>	<input type="checkbox"/>
Did Envirotronics select the carrier for this shipment?.....	<input type="checkbox"/>	<input type="checkbox"/>

Equipment

	Yes	No
Did the equipment you received match what you feel you had ordered?.....	<input type="checkbox"/>	<input type="checkbox"/>
Does the equipment perform as expected?.....	<input type="checkbox"/>	<input type="checkbox"/>
Did you order an "equipment start-up"?.....	<input type="checkbox"/>	<input type="checkbox"/>
Have you purchased any spare parts?.....	<input type="checkbox"/>	<input type="checkbox"/>
Who performs the calibrations & maintenance service on your environmental test equipment? _____		
Does your Envirotronics equipment ... <input type="checkbox"/> exceed your expectations? <input type="checkbox"/> meet your expectations? <input type="checkbox"/> fall short of your expectations?		
Would you purchase equipment from Envirotronics again?.....	<input type="checkbox"/>	<input type="checkbox"/>

Comments



HOW TO USE THIS MANUAL

This manual is presented as a general guide to assist in the installation, start up, operation, trouble shooting and preventive maintenance for your Envirotronics equipment.

Some of the instructions and procedures may not apply to your specific chamber.

Images used in this manual may not match your equipment exactly. Use them only as a general guide.

For information regarding installation of your chamber, refer to the section titled **Installation**.

For information regarding start Up and Operation of your chamber, refer to the section titled **Start Up / Operation**

For information regarding troubleshooting and maintenance of your chamber, please refer to the section titled **Troubleshooting / Maintenance / Calibration / Service**

For information regarding your chamber's specifications, description, instrument manual(s), drawings , and other information specific to your equipment, please refer to the section **Information About Your Equipment**.

NAVIGATION

Bookmarks have been provided to the various sections of your manual. Click on the desired bookmark in the Bookmarks Tab Window located in the left panel to go to the desired section.



Envirotronics™

**3881 N. Greenbrooke S.E.
Grand Rapids, MI 49512**

Tel: (800) 368-4768 • (616) 554-5020

Fax: (800) 791-7237 • (616) 554-5021

**Email: sales@envirotronics.com
service@envirotronics.com**

Web: www.envirotronics.com



COMPLIANCE

All Envirotronics equipment is manufactured in compliance with the appropriate military standards, ASTM specifications, and/or customer purchase-order-specified requirements.

Envirotronics' power panels are in compliance with UL508A First Edition dated April 25, 2001, NFPA79 requirements, and ETL labeled. Equipment shipping into Canada is certified to CAN/CSA C22.2 NO.14 and ETL labeled. Equipment shipping into the European markets, where applicable, has C.E. "Declaration of Conformity" certificates provided and is in compliance with European standards. When incorporated in equipment purchase specifications, our equipment is manufactured to conform to SEMI S2-0200, and SEMI S8-1000 guidelines

SCOPE/GENERAL INFORMATION

Envirotronics has prepared this manual to assist you during installation, start-up and operation of your environmental test equipment. You can download a copy of Envirotronics' Systems Plus or Solutions Plus manual from our website www.envirotronics.com. Please keep in mind this manual is generic to our equipment there may be options described you did not purchase. Please refer to equipment specification page or your purchase order.

It is recommended that you read the manual and electrical safety instructions prior to starting up the equipment, and follow proper Lock-out-Tag out (LOTO) procedures, electric, air, and water supply lines. Also, allow access and clearance of 48" in front of all electrical enclosure or where electrical work is to be performed.

We recommend that the manual be located in an accessible location. If service is required, the manual should be readily available to aid in the troubleshooting process.

Included in this manual, you will find a system start-up checklist. This checklist is a brief listing of the major items covered in this manual. Please refer to the appropriate sections to assure a smooth and safe start-up. Envirotronics also recommends proper training for use of your new equipment. Contact Envirotronics' Service Department for cost and availability for this service @ 1-800-368-4768 or email <service@envirotronics.com>.

An integral part of the manual is our warranty statement. We have also included a recommended list of spare parts that you may wish to purchase.

NOTICE SIGNAL WORDS:

Signal Word: The word or words that call attention to the safety sign and designate a degree or level of hazard seriousness. The signal words for product safety signs are **DANGER**, **WARNING**, and **CAUTION**.

DANGER: Indicates an imminently hazardous situation which, if not avoided, will result in death or serious injury. This signal word is to be limited to the most extreme situations.

WARNING: Indicates a potentially hazardous situation which, if not avoided, could result in death or serious injury.

CAUTION: Indicates a potentially hazardous situation which, if not avoided, may result in minor or moderate injury. It may also be used to alert against unsafe practices.

MSDS: *Documentation is located in back of this manual for any hazardous chemicals shipped or contained with your new equipment.
Personal protection equipment, defined by the MSDS, should be used as instructed.*

In case of emergency please post an appropriate phone number for your personnel to call for immediate help.

GENERAL INFORMATION

THE MATERIALS OF CONSTRUCTION BREAKDOWN:

TYPE	PERCENT	REMARKS
STEEL	65%	
STAINLESS STEEL	25%	
COPPER	5%	
ELECTRICAL COMPONENTS	5%	NON-FLAMMABLE
OTHER	TYPE/AMT	
REFRIGERANT	404A(HP62)6#	NON-FLAMMABLE
OIL	SL32SC .5 GAL	

Note: Other oils or refrigerants may be used in your chamber



Installation and Equipment Relocation

Installation and Relocation of Environmental Test Systems

Complex environmental test equipment requires technicians skilled in proper installation to ensure reliable performance. Whether your installation is as simple as wiring the interconnect of a remote control console, piping for a remote air-cooled condenser, or assembling a panel construction walk-in or drive-in chamber on site, Envirotronics field construction personnel have the knowledge and experience to get the job done right for you.

In today's business world, circumstances may require that your existing environmental test equipment be relocated. Whether your equipment needs to be relocated to another part of your facility or to a facility in another part of the world, Envirotronics' field construction personnel, once again, are ready to meet your requirements.

Envirotronics employs personnel dedicated to installing new equipment, used equipment, disassembly, moving, and reassembly of equipment. As all services offered by Envirotronics, installation and system relocations are available on all makes and models of environmental test equipment.

Do you have a system that is in need of installation or relocation? Please contact Envirotronics' Customer Support Group for more information and/or a quote.



When you contact us regarding your installation or relocation, be sure to ask about how you can be a part of our Value Plus Program.

***Contact our Customer Support Group today!
Tel: 616-554-5022 • Fax: 616-554-5024
• Email: service@envirotronics.com***



Envirotronics[®]

3881 N. Greenbrooke S.E.
Grand Rapids, MI 49512

Tel (800) 368-4768 • (616) 554-5020

Fax (800) 791-7237 • (616) 554-5021

Email sales@envirotronics.com

service@envirotronics.com

Web www.envirotronics.com



CHAMBER INSTALLATION

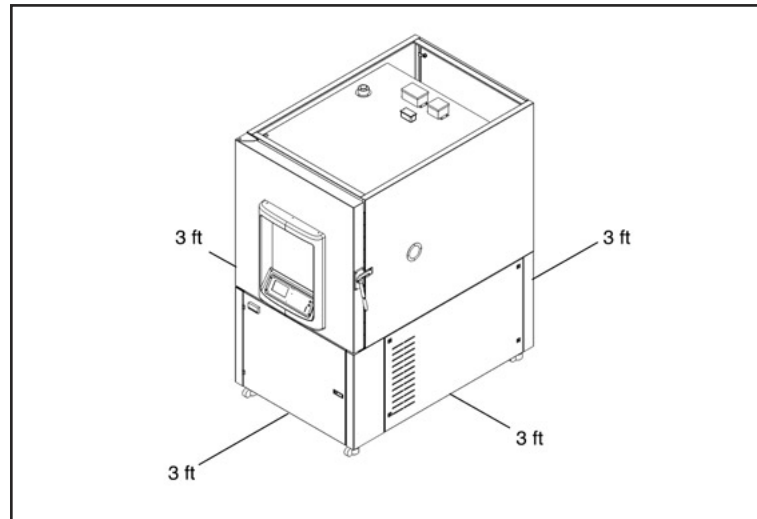

First, locate the area in which your chamber will be installed. Check the area selected for its serviceability to the machinery compartments, both electrically and mechanically. In the event your equipment is too large to move through halls and doorways, consult factory as to what can be detached for the move in.

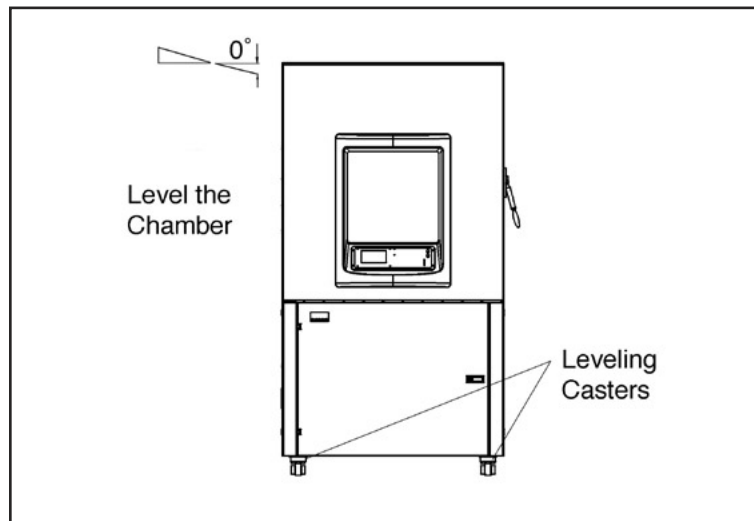

Place equipment in desired location, reinstall any detached components that had been detached through arrangements with Envirotronics for the move in. We recommend that the chamber and machinery compartment (being either a self-contained system or component system) be leveled. Leveling helps assure the systems' optimum performance promoting good oil return on the refrigeration system and proper drainage of any accumulated moisture.

INSTALLATION & START UP SAFETY INSTRUCTIONS

Follow all **WARNINGS** to prevent personal injury or death.

- WARNING:** To safely install the chamber, you must read the **General Safety Instructions**.
- WARNING:** To install or start up the chamber you must read the applicable instructions in this manual. If you need help, contact the nearest Envirotronics Field Service Office.
- WARNING:** Do not perform the start-up procedure until all other installation is complete. Before starting up the chamber, you must read the operating instructions.
- WARNING:** Dangerously high voltages are present. Do not turn on the electrical power until you are instructed to do so in the start -up procedure. Check your Lock-Out / Tag-Out Procedures.
- WARNING:** Disconnect the electrical power before working near moving parts. Keep all guards and shields in place. Use your Lock-Out / Tag-Out Procedures.
- WARNING:** Before service or repair allow chamber to cool to ambient room temperature before entry.
- WARNING:** If your chamber has an LN₂, or GN₂ injection system make sure it is vented according to the instructions on LN₂ Cooling. If the LN₂, GN₂ is injected directly into the test space, nitrogen gas or carbon dioxide gas is left in the chamber test area. This gas must be adequately diluted by the surrounding room air. Using the chamber in a poorly ventilated area results in a lack of oxygen, which could cause death.

Follow all **CAUTIONS** to prevent equipment damage

- CAUTION:** Use the electrical power supply shown on your chamber's electrical drawing and serial tag. Air, water, and other supplies must be within the limits shown in the applicable instructions or drawings.
- CAUTION:** This equipment is heavy; use the proper equipment to move it. Do not put strain on pipes or external components.

GENERAL SAFETY INSTRUCTIONS

Read all **WARNINGS** to prevent personal injury and death.

- WARNING:** Do not operate this chamber unless it is completely assembled.
- WARNING:** This chamber operates at extreme temperatures. To prevent severe burns or frostbite, avoid contact with air, objects, and surfaces that are hot or cold.
- WARNING:** Use this chamber only for testing the products it was designed to test. Do not put products in the chamber that could burn or explode at high temperatures.
- WARNING:** Make sure all warning labels remain attached to the chamber. If needed, order new labels from Envirotronics Service Department .
- WARNING:** Make sure the door(s) are closed while the chamber is operating. Before opening the door, make sure the blower wheels are not rotating, and make sure the test space is near room temperature.
- WARNING:** The gases from GN2 purge systems and, LN2 injection systems, displace regular room air and can cause you to suffocate. To safely install and use these systems, you must follow the instructions on the material containers, the installation instructions in the LN2 Cooling section of this manual.
- WARNING:** Dangerously high voltages that could kill you are present in the electrical system. Before doing any electrical work, disconnect the electrical power with Main Power Disconnect switch.
- WARNING:** Before working near moving parts, disconnect the electrical power with the Main Power Disconnect switch. Keep all guards and shields in place. If your system has refrigeration compressors with Pump Down Pressure Switches (PDPS), they can start at ANY time while the main power is connected - even when the chamber is not operating. Keep fingers away from compressors head fans. Use LOTO Procedures.
- WARNING:** This manual has important safety information. All users must read. Before installing or starting up the chamber, read instructions. Before operating the chamber, read instructions, before performing maintenance, read instructions, before servicing the chamber, read instructions. Safety instructions may also appear in instrumentation manuals supplied with this chamber. Keep this manual in a place where it will be available to anyone working with the chamber.
- WARNING:** If you work with a hazardous material, read the MSDS (Material Safety Data Sheet) and the safety instructions on the container and provide proper personal protective equipment as instructed by MSDS.
- WARNING:** When accessing disconnect for air filters use an OSHA approved ladder, *such as the one supplied By McMaster-Carr P/N 8188T88 (Ladder 48" with handrails) that meets OSHA and Ansi A14.7 standards or equipment.*

WATER SYSTEM INSTALLATION

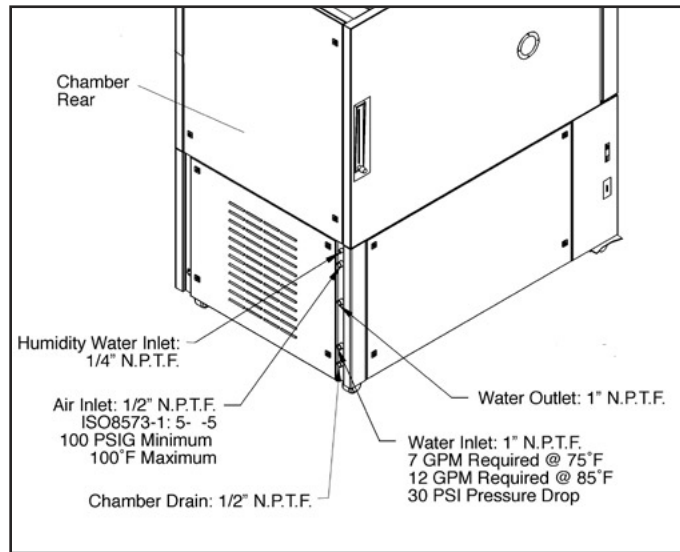

On water cooled systems, connect the inlet water line to the line marked condenser inlet. Connect the drain side of the line to the connection marked condenser outlet.

The water valves are rated at 100 p.s.i. maximum. **DO NOT EXCEED THE PRESSURE.** Water connections should be made with a line connection of at least the same size as the inlet and outlet fittings.

CAUTION: RISK OF ELECTRICAL SHOCK. DISCONNECT POWER BEFORE SERVICING UNIT. USE LOTO Procedures.

ELECTRICAL INSTALLATION

Electrical power for your test chamber is typically supplied in one of two methods.

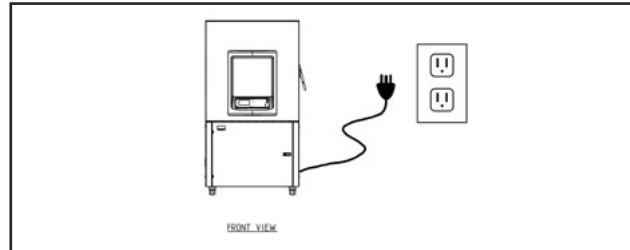

One method of connecting your test chamber to electrical power is with the use of a receptacle and plug. Before connecting power, verify current voltage and phase of your chamber. This information is located on the equipment's specification page and on the electrical drawing. If you have any questions regarding your chamber power requirements, please consult the factory. The use of improper power can void your warranty.

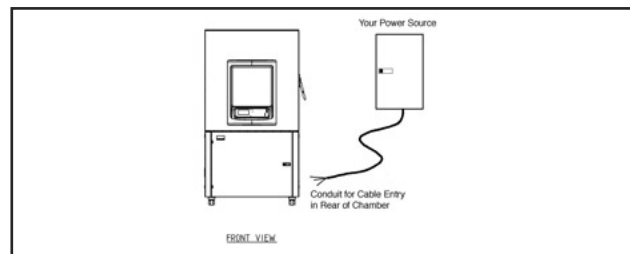

Another method of connecting electrical power to your equipment is by hard wiring. A main power distribution block or a main power disconnect (optional) will be located in the electrical compartment for this purpose. Again verify that proper voltage and current requirements have been supplied according to the information on the equipment specification page and on the electrical drawing.

For questions regarding wire sizing, conduit sizing or conduit piping practices, please consult a licensed contractor in your area or your facilities manager. State, local and company codes govern the methods and practices used on installation of electrical hook ups and use your LOTO Procedures.

WARNING: Dangerously high voltages are present. Do not turn on the electrical power until you are instructed to do so in the start -up procedure.

WARNING: Disconnect the electrical power before working near moving parts. Keep all guards and shields in place.

ELECTRICAL SYSTEM

An electrical system drawing has been included in this manual. Please refer to the drawing during the following explanation of the system.

You will note in the upper left hand corner of the drawing, the appropriate voltage and current requirements of the system. Before applying power to the system, verify that the appropriate electrical service has been supplied.

There are numbers running vertically along the left side of the print. These are line numbers that allow you to utilize the information given along the right hand side. Along the right side of the circuitry, you will find line identifications and numbers. These numbers will indicate what line(s) a component such as a contactor (or relay) has contacts located. Multiple line numbers indicate that there are several contacts.

The print shows all of the wires located within the system. The main control wires have been returned to the main terminal strip within the electrical enclosure for ease of troubleshooting.

Please note that all high voltage components have a current rating shown on the drawing. It is generally recommended that these readings be checked during the start-up procedure. During normal calibration or preventive maintenance checks, it is recommended that current readings be taken to verify that everything is in good working condition. Readings should be within +/-10% of the ratings shown on the drawings.

If a high-heat limit is shown on the drawing, it is recommended that the performance of this limit be checked periodically. Simply adjust the temperature setting of the high heat limit (typically set at 360° F) to a lower value and verify that it trips. Once the device is tripped, a manual reset is required.

WARNING: Dangerously high voltages are present. Do not turn on the electrical power until you are instructed to do so in the start -up procedure.

WARNING: Disconnect the electrical power before working near moving parts. Keep all guards and shields in place.

ELECTRICAL SYSTEM (Continued)

The following legends are typical on Envirotronics' system drawings:

- C - Circulator Motor Contactor:** This applies power to the circulator motor(s).
- MH - Master Heat Contactor:** This is a safety contactor that powers the heaters. This contactor can only be energized if all safety devices are within limits.
- H1,H2, H3 - Heat Relays:** These are control contactors that apply power to the heaters. The H2 or H3 contactors are normally operated on a time delay (TD) output following H1 being put into demand.
- CR - Control Relay:** This is used to either energize or de-energize solenoids or other control devices.
- CF - Condenser Fan Contactor:** This applies power to the condenser fan motors (on air cooled systems).
- HF - Head Fan Contactor:** This applies power to the head fans (when applicable).
- TD or TR - Time Delay Relay:** This is used either to time on or off control devices.
- EVR - Event Relay:** This is used either to turn on or off other control devices.
- Compressor Contactors:** These will be identified by either HS (High Stage) or LS (Low Stage)
*Note: HS indicates the R404A side of the system.
LS indicates the R508B side.*

The following legends are for humidity systems only:

- MW - Master Water Contactor:** This is a safety contactor which powers the heaters. This contactor can only be energized if all safety devices are within limits.
- W1 - Water Relay:** This is an additional contactor that applies power to the humidity elements.

WARNING: Dangerously high voltages are present. Do not turn on the electrical power until you are instructed to do so in the start -up procedure.

WARNING: Disconnect the electrical power before working near moving parts. Keep all guards and shields in place.

LN2 BOOST INSTALLING A GN2, LN2, SYSTEM

WARNING: Improper installation of a GN2 (gaseous nitrogen), or LN2 (liquid nitrogen), system can cause death by suffocation. Make sure the chamber is vented to the following instructions.

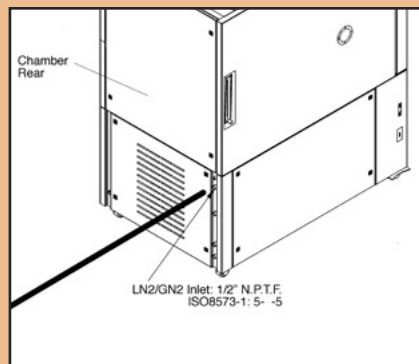
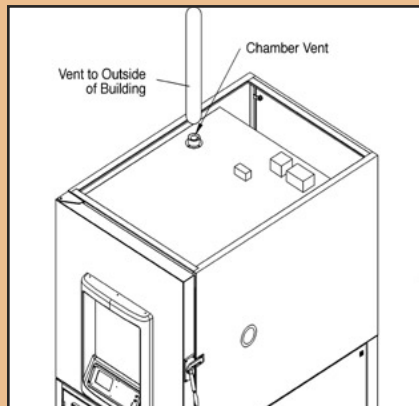

1. Connect a vent line from the chamber vent, located on top of the chamber, to the outside of the building.

- Make sure the vent outlet is not near a fresh air intake to the building.
- To prevent back pressure, the vent line must be short, straight, and at least as large in diameter as the chamber vent.
- If your chamber has more than one vent, repeat this step for the other vent(s).

2. Find the GN2, LN2 inlet on the chamber (the assemblies are labeled), and connect the needed supply:

- For GN2 systems, connect a gaseous nitrogen supply to the inlet at a maximum pressure of 100 psig.
- For LN2 systems, connect a liquid nitrogen supply to the inlet at a maximum pressure of 80 psig. Include a high-pressure relief valve in the line, and insulate the line.

3. Use a leak-detecting solution to check for leaks.

The cooling portion of this Envirotronics Test Chamber is being enhanced through direct injection of liquid nitrogen. This is used as a boost for faster pulldown rates.

The system utilizes a redundant solenoid as well as a control solenoid. The redundant solenoid is enabled whenever there is a cooling command.

The control solenoid circuit is enabled via a delay timer. This timer setting should be great enough to avoid overshooting at control. A repeat cycle timer is also energized (sometimes called a percentage timer) cycling the control solenoid off.

LN2 BOOST INSTALLING A GN2, LN2, SYSTEM (Continued)

then back on. This repeat cycle timer can be changed to vary the pulldown rates. An indicator light next to the function switch will indicate when the LN2 control solenoid is open.

Power will be de-energized to the LN2 boost circuit when the cooling output of the controller starts pulsing as the chamber nears the setpoint.

WARNING: Avoid exposing yourself to air and equipment that is not at room temperature. Please check the equipment nomenclature to see if the LN2 boost applies to your chamber.

LN2 COOLING INSTALLING A GN2, LN2, SYSTEM

WARNING: Improper installation of a GN2 (gaseous nitrogen), or LN2 (liquid nitrogen), system can cause death by suffocation. Make sure the chamber is vented to the following instructions.

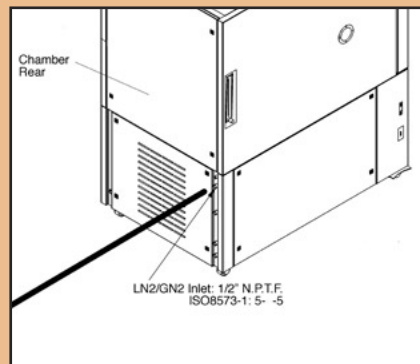
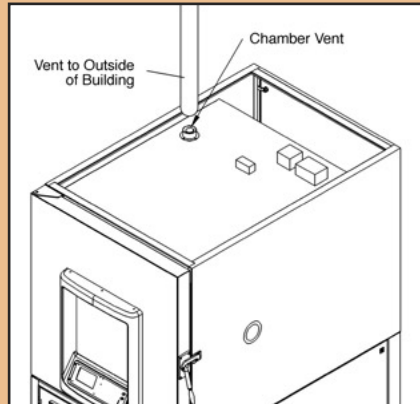

1. Connect a vent line from the chamber vent, located on top of the chamber, to the outside of the building.

- Make sure the vent outlet is not near a fresh air intake to the building.
- To prevent back pressure, the vent line must be short, straight, and at least as large in diameter as the chamber vent.
- If your chamber has more than one vent, repeat this step for the other vent(s).

2. Find the GN2, LN2 inlet on the chamber (the assemblies are labeled), and connect the needed supply:

- For GN2 systems, connect a gaseous nitrogen supply to the inlet at a maximum pressure of 100 psig.
- For LN2 systems, connect a liquid nitrogen supply to the inlet at a maximum pressure of 80 psig. Include a high-pressure relief valve in the line, and insulate the line.

3. Use a leak-detecting solution to check for leaks.

The cooling portion of this Envirotronics' Test Chamber is through direct injection of liquid nitrogen.

The system utilizes a redundant solenoid as well as a Baumann LN2 control valve. The redundant solenoid is enabled when the cool switch has been turned on and the controller is calling for cooling. The redundant solenoid will close after there hasn't been a cooling demand for 90 seconds.

The Baumann I/P positioner receives a linear 4-20mA signal from the controller.

LN2 COOLING INSTALLING A GN2, LN2, SYSTEM (Continued)

The positioner converts this signal to an air pressure based on the following formulas $4-20\text{mA} = 3-15\text{ psig}$. The air pressure then opens the control valve allowing LN2 to be injected into the chamber. When the chamber nears the setpoint, the pressure will be reduced allowing the valve to close, thereby reducing the flow of LN2. An indicator light next to the function switch will illuminate when there is a cooling signal to the I/P converter.

Your chamber is equipped with a Baumann Series 763 Single-Acting Positioner. Before operation, you may need to verify calibration. Sometimes during shipment, settings may change. Use operation instructions contained in this manual to re-calibrate if required. If you require further assistance with this procedure, please call Envirotronics' Product Support Group.

**Envirotronics Product Support Group: 1-800-368-4768
616-554-5022**

WARNING: Avoid exposing yourself to air and equipment that is not room temperature.

LN2 COOLING THROUGH COIL INSTALLING A GN2, LN2, SYSTEM

WARNING: Improper installation of a GN2 (gaseous nitrogen), or LN2 (liquid nitrogen), system can cause death by suffocation. Make sure the chamber is vented to the following instructions.

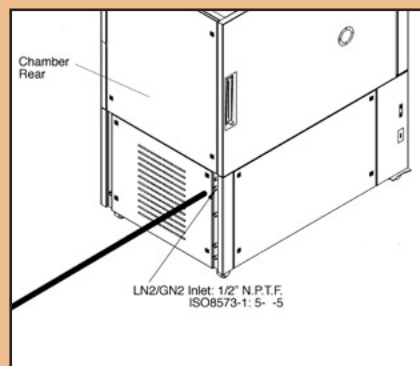
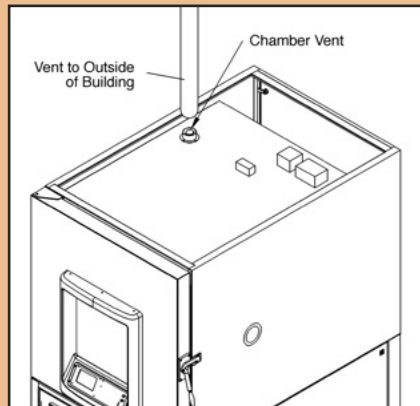

1. Connect a vent line from the chamber vent, located on top of the chamber, to the outside of the building.

- Make sure the vent outlet is not near a fresh air intake to the building.
- To prevent back pressure, the vent line must be short, straight, and at least as large in diameter as the chamber vent.
- If your chamber has more than one vent, repeat this step for the other vent(s).

2. Find the GN2, LN2 inlet on the chamber (the assemblies are labeled), and connect the needed supply:

- * For GN2 systems, connect a gaseous nitrogen supply to the inlet at a maximum pressure of 100 psig.
- For LN2 systems, connect a liquid nitrogen supply to the inlet at a maximum pressure of 80 psig. Include a high-pressure relief valve in the line, and insulate the line.

3. Use a leak-detecting solution to check for leaks.

The cooling portion of this Envirotronics' Test Chamber is the evaporation of liquid nitrogen through an evaporator coil.

The system utilizes a redundant solenoid as well as a Baumann LN2 control valve. The redundant solenoid is enabled when the cool switch has been turned on and the controller is calling for cooling. The redundant solenoid will close after there hasn't been a cooling demand for 90 seconds.

The Baumann I/P positioner receives a linear 4-20mA signal from the controller.

**LN2 COOLING THROUGH COIL
INSTALLING A GN2, LN2, SYSTEM (Continued)**

The positioner converts this signal to an air pressure based on the following formulas $4-20\text{mA} = 3-15\text{ psig}$. The air pressure then opens the control valve allowing LN2 to flow through the evaporator coil. When the chamber nears the setpoint, the pressure will be reduced allowing the valve to close, thereby reducing the flow of LN2. An indicator light next to the function switch will illuminate when there is a cooling signal to the I/P converter.

Your chamber is equipped with a Baumann Series 763 Single-Acting Positioner. Before operation, you may need to verify calibration. Sometimes during shipment, settings may change. Use operation instructions contained in this manual to re-calibrate if required. If you require further assistance with this procedure, please call Envirotronics' Product Support Group.

**Envirotronics Product Support Group: 1-800-368-4768
616-554-5022**

WARNING: Avoid exposing yourself to air and equipment that is not near room temperature.

REFRIGERATION SYSTEM INSTALLATION

Prior to starting any refrigeration system, the following checks should be made.



1. Verify that all refrigeration lines remained secure during shipment.
2. Look for the presence of fractured lines. This is sometimes indicated by the presence of an oil mist coating lines and components.



3. Backseat all valves with yellow tags prior to start-up. Your system has been pumped down for shipment. (If applicable to your chamber.) Reference yellow sheet on the inside of the electrical box door. Initials on this sheet will indicate the number of valves front seated.

REFRIGERATION SYSTEM INSTALLATION (Continued)

CAUTION: To remove compressor, heavy component: Compressor weighs 65#. To safely remove, you should first slide the compressor towards the rear of the (tool) chamber before attempting to lift it. This requires a two-person lift.

REFRIGERATION SYSTEM

The refrigeration portion of your Envirotronics’ test chamber may be configured in one of many variations, based on the size of the compressors. Refer to the enclosed system drawing during the following explanations of system operation. Envirotronics recommends using a trained refrigeration technician or call or email Envirotronics’ Service Department for help and cost to assist (Tel: 616-554-5022 or service@envirotronics.com).

By referring to the electrical drawing, you are able to determine which safety devices have been installed in your system. These devices will be located directly to the left of the compressor safety relay (generally marked CR2). Typically, there are from two to six safety devices, depending on the size of the system.

The high-low pressure switches are intended to monitor the pressures within the individual refrigeration systems. If the high-low pressure switch(es) are tripped, they must be reset manually. Do not reset more than twice without consulting the factory.

The two oil pressure switches monitor the oil pressure within the compressors. Oil level within Carlyle compressors should be between the 1/8 and Copeland compressors should be between 1/3 and 1/2 level. If improper oil levels are observed, our Product Support Group should be contacted.

Inherent overload protection may also be included in the compressors. If tripped, these devices must cool down before they reset themselves. If the inherent protection is tripped, our Product Support Group should be contacted

**Envirotronics Product Support Group: 1-800-368-4768
616-554-5022**



Note: With units that utilize the Systems Plus: after resetting manually, the alarm ACK key must be pressed and then the alarm reset key depressed on the Systems Plus to return to normal operation.

CAUTION: ONLY QUALIFIED SERVICE PERSONNEL SHOULD ATTEMPT TO CHARGE AN R23 SYSTEM. REFRIGERANT 23 IS 610 PSIG AT AMBIENT TEMPERATURE. EXTREME CARE SHOULD BE USED IN HANDLING THIS REFRIGERANT.

R23 REFRIGERATION SYSTEM CHARGING PROCEDURE

To verify that the R23 pressures are normal, first look at the serial tag located within the electrical compartment. Compare the actual pressure with the pressure required.

To obtain the system standby (actual) pressure, follow this procedure:

1. Backseat the suction and discharge service valves on the R23 compressor; valves turned all the way counterclockwise.
2. Connect a set of manifold gauges to the system, suction gauge to suction service valve and discharge gauge to discharge service valve. Attach the center hose to the tank of R23. Prior to allowing gas to enter the system, the hoses should be evacuated by using a vacuum pump or an EPA recognized method of purging the hoses.
3. After the lines have been either evacuated or purged, close the R23 tank and tighten all of the fittings. Then open both the suction and discharge valves 1/2 turn. The standby pressure of the system will now be observed on the gauges. Proper charges will be read only if the chamber and cascade condenser are stabilized at ambient temperature.

If, after observing standby pressure, it is determined that additional gas is required, follow this procedure:

1. Leak check entire system with either electronic or Halide leak detectors.
2. Repair leaks as necessary.
3. Evacuate system.
4. Attach manifold as previously discussed.
5. Open both manifold valves and open the R23 tank to allow gas to flow into the system. When the gauges record the proper standby, close the valve on the R23 tank. Allow the chamber to stand for 15 minutes to stabilize the pressure. If required, add additional R23 and repeat the above procedure until the proper standby pressure is maintained.
6. After the proper pressure has been maintained, close both manifold valves (clockwise) and the R23 tank valve.
7. Allow the system to run and verify operating pressures.
8. If pressures are normal, backseat the compressor service valves and remove the gauges.

CAUTION: ONLY QUALIFIED SERVICE PERSONNEL SHOULD ATTEMPT TO CHARGE A SUVA HP95 SYSTEM. SUVA HP95 IS 610 PSIG AT AMBIENT TEMPERATURE. EXTREME CARE SHOULD BE USED IN HANDLING THIS REFRIGERANT.

SUVA HP95 REFRIGERATION SYSTEM CHARGING PROCEDURE

To verify that the SUVA HP95 pressures are normal, first look at the serial tag located within the electrical compartment. Compare the actual pressure with the pressure required.

To obtain the system standby pressure, follow this procedure:

1. Backseat the suction and discharge service valves on the SUVA HP95 compressor; valves turned all the way counterclockwise.
2. Connect a set of manifold gauges to the system, suction gauge to suction service valve and discharge gauge to discharge service valve. Attach the center hose to the tank of SUVA HP95. Prior to allowing gas to enter the system, the hoses should be evacuated by using a vacuum pump or an EPA recognized method of purging the hoses.
3. After the lines have been either evacuated or purged, close the SUVA HP95 tank and tighten all of the fittings. Then open both the suction and discharge valves 1/2 turn. The standby pressure of the system will now be observed on the gauges. Proper charges will be read only if the chamber and cascade condenser are stabilized at ambient temperature.

If, after observing standby pressure, it is determined that additional gas is required, follow this procedure:

1. Leak check entire system with either electronic or Halide leak detectors.
2. Repair leaks as necessary.
3. Evacuate system.
4. Attach manifold as previously discussed.
5. Open both manifold valves and open the SUVA HP95 tank to allow gas to flow into the system. When the gauges record the proper standby, close the valve on the SUVA HP95 tank. Allow the chamber to stand for 15 minutes to stabilize the pressure. If required, add additional SUVA HP95 and repeat the above procedure until the proper standby pressure is maintained.
6. After the proper pressure has been maintained, close both manifold valves (clockwise) and the SUVA HP95 tank valve.
7. Allow the system to run and verify operating pressures.
8. If pressures are normal, backseat the compressor service valves and remove the gauges.

CAUTION: ONLY QUALIFIED SERVICE PERSONNEL SHOULD ATTEMPT TO CHARGE AN R404A SYSTEM.

R404A REFRIGERATION SYSTEM CHARGING PROCEDURE



The R404A system is not charged by standby pressures. To monitor the R404A system, turn the system on and set in a low temperature set point so that the system is reducing the chambers temperature (pulldown). After 2 minutes of operation, observe the sightglass. The sightglass should be free of all bubbles. If not, additional R404A is required.

To charge the system, proceed as follows:

1. Backseat the suction and discharge service valves on the R404A compressor. Valves turned all the way counterclockwise.
2. Connect a set of manifold gauges to the system, suction gauge to suction service valve and discharge gauge to discharge service valve. Attach the center hose to the tank of R404A. Prior to allowing gas to enter the system, the hoses should be evacuated by using a vacuum pump or an EPA recognized method of purging the hoses.
3. After lines have been either evacuated or purged, close the R404A tank and tighten all fittings. Then open both the suction and discharge valves 1/2 turn. The pressure of the system will now be observed on the gauges.
4. Allow the system to operate for 2 minutes (minimum).
5. Open the suction manifold only. **DO NOT PUT R404A INTO THE DISCHARGE PORT.** Allow liquid refrigerant to flow into the suction side until the sightglass becomes clear. Do not allow suction pressure to exceed 50 PSI while adding liquid refrigerant.
6. Continue to monitor the sightglass during the pulldown and if required, add more R404A.
7. After the bubbles clear, backseat the compressor valves, frontseat the manifold valves and remove the gauges.

CAUTION: ONLY QUALIFIED SERVICE PERSONNEL SHOULD ATTEMPT TO CHARGE AN R507 SYSTEM.

R507 REFRIGERATION SYSTEM CHARGING PROCEDURE



The R507 system is not charged by standby pressures. To monitor the R507 system, turn the system on and set in a low temperature set point so that the system is reducing the chambers temperature (pulldown). After 2 minutes of operation, observe the sightglass. The sightglass should be free of all bubbles. If not, additional R507 is required.

To charge the system, proceed as follows:

1. Backseat the suction and discharge service valves on the R507 compressor. Valves turned all the way counterclockwise.
2. Connect a set of manifold gauges to the system, suction gauge to suction service valve and discharge gauge to discharge service valve. Attach the center hose to the tank of R507. Prior to allowing gas to enter the system, the hoses should be evacuated by using a vacuum pump or an EPA recognized method of purging the hoses.
3. After lines have been either evacuated or purged, close the R507 tank and tighten all fittings. Then open both the suction and discharge valves 1/2 turn. The pressure of the system will now be observed on the gauges.
4. Allow the system to operate for 2 minutes (minimum).
5. Open the suction manifold only. **DO NOT PUT R507 INTO THE DISCHARGE PORT.** Allow liquid refrigerant to flow into the suction side until the sightglass becomes clear. Do not allow suction pressure to exceed 50 PSIG while adding liquid refrigerant.
6. Continue to monitor the sightglass during the pulldown and if required, add more R507.
7. After the bubbles clear, backseat the compressor valves, frontseat the manifold valves and remove the gauges.

JACK SHAFT / BLOWER WHEEL INSTALLATION

If your equipment has fan blades, disregard this section.



The jack shaft(s) and blower wheel(s) combination may have been removed from this environmental test chamber due to shipping height considerations. Please follow this procedure to insure proper performance and reliability.

1. Mount this jack shaft assembly on the top of the chamber in the orientation shown on your assembly drawing. The bolts needed have been placed back in their proper holes on top of the chamber. Remove these before setting the jack shaft assembly in place, on top of the 1/8" thick neoprene gasket. Bolt down the jack shaft assembly with the bolts, lock washers and flat washers provided.

2. Now that this is done, determine the shaft that each blower wheel will mount on. (This will be marked on each wheel.) Remove the inlet cone(s) from the plenum. Inspect the interior shafts and blower wheel. The shaft also has a washer and a LH threaded screw tapped into its end; remove these for blower installation.

Note on the blower wheel, the two set screw locations. There are two set screws per hole; the second one is to lock the first set screw in position. Each set screw must be prepared with the removable "loctite".

3. Prepare each set screw with "loctite" and thread into the tapped hole without protruding into the bore. Insert the keyway into the keyseat and slide the blower wheel onto the appropriate shaft. The back plate of the blower wheel should be approximately 1" from the chamber liner.

4. Align the set screw to the drill cup located on keyways and tighten to the shaft. Then thread the "jam" set screws into each tapped hole and tighten. Replace the washer and LH bolt in the end of the shaft and tighten. Repeat this paragraph for each blower wheel.

JACK SHAFT / BLOWER WHEEL INSTALLATION (Continued)

5. Re-install the inlet cone for each wheel, make sure the wheel will not rub on the inlet cone when spinning. Make any appropriate adjustments.
6. Make sure all bolts and set screws are tight. Then re-connect the liquidtight conduit to the motor(s); wire as shown on the motor nameplate. The final step is to attach the jack shaft guard to the jack shaft framework.

LUBRICATION PROCEDURE

Lubricating the fan shaft bearings is a very important preventive maintenance procedure that must be upheld in order to extend bearing life.

It is recommended that the bearings be lubricated once every month for a chamber that is operating 40 hours per week or greater and once every two months for a chamber that is operating 20-40 hours per week. The recommended lubricant is Dow Corning BR2-Plus or a grease conforming to NLGI grade #2.

When lubricating the fan shaft bearing, it is best to look at the bearings to prevent over-greasing. Add grease to each bearing until the first sign of grease is exiting out from between the bearing and the outer race. This is a sign that the bearing is properly lubricated. The recommended amount of grease is 1 to 2 strokes (5/8 to 7/8 oz.) with a standard grease gun.

Follow the above directions very carefully to maintain optimum performance characteristics. Please call Envirotronics' Product Support Group if there are any questions regarding this procedure.

**Envirotronics Product Support Group: 1-800-368-4768
616-554-5022**

HUMIDITY SYSTEM

Envirotronics offers two different types of humidity systems. The first is a Mechanical Humidity System or steam generator type. The second being an Atomizing Humidity System.

It is very important to determine which type of humidity is incorporated in your environment test chamber. Please consult Envirotronics' Product Support Group.

**Envirotronics Product Support Group: 1-800-368-4768
616-554-5022**

Over Temp Check Out Procedure

- Step #1 Use LOTO procedure for electric and water.
- #2 Drain Steam Generator tank of water
 - #3 Apply power per LOTO procedures (remove LOTO tags per your companies LOTO).
 - #4 Monitor temperature to 250°F. Watch for trip condition to shut down heater.
 - #5 Reset temperature controller. Turn water on to re-fill steam generator tanks.
 - #6 Verify steam generator is heating properly.

REPEAT PROCEDURE QUARTERLY

Please be aware this checkout procedure may cause damage to heater and or cause replacement.

MECHANICAL HUMIDITY WATER REQUIREMENTS

On a humidity system, water is required for the steam generator. Also, systems not utilizing a solid state humidity sensor may use a wick tank to measure wet bulb temperature for relative humidity measurements. If a wick tank is included, periodic replacement of the wet sock is required. It is recommended that the wet sock is replaced once a week or prior to a test that has a duration of more than two weeks. Systems incorporating a water demineralizer require periodic cartridge replacement determined by the quality of water you utilize. Connect humidity inlet water to the connection provided marked humidity water inlet. Water levels in the wick tank and the steam generator are controlled automatically by individual float mechanisms.

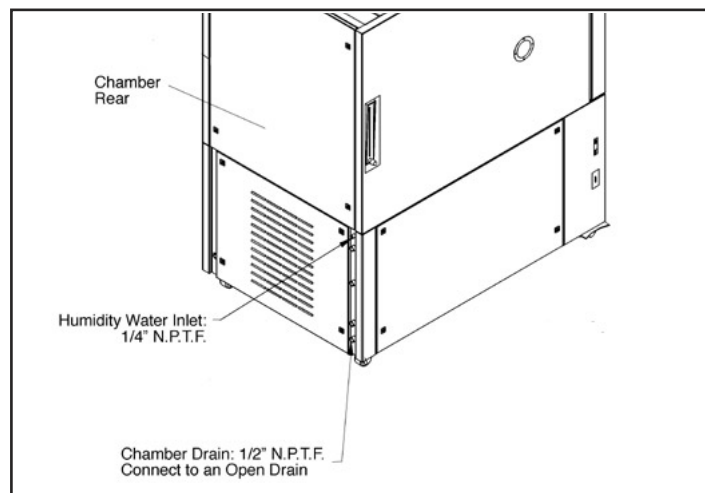

The humidity water outlet should be connected to an open drain.

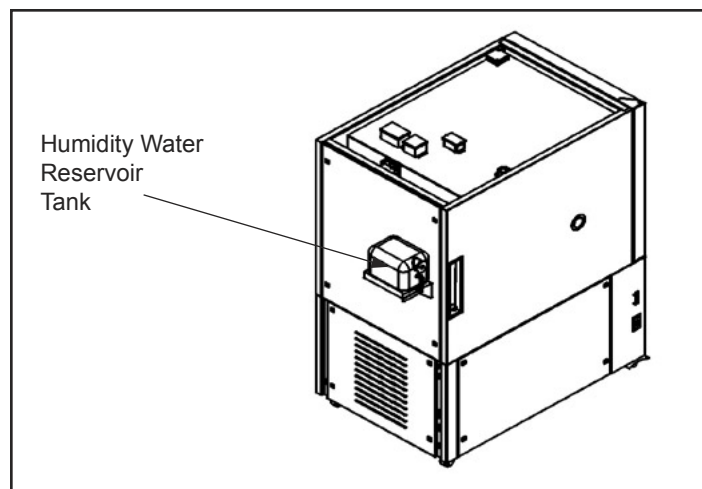

If your system utilizes a reservoir tank, the tank must be placed on top or at an elevation higher than the chamber.

MECHANICAL HUMIDITY WATER REQUIREMENTS (Continued)

Humidity water quality is an important issue for the customer to consider. Humidity systems require water that is neither scale forming nor corrosive. It is recommended that humidity water should have a specific resistance in the range of 50,000 to 200,000 ohms. Water that is super pure or impure will cause problems in the system. Optional demineralizers to remove impurities from the water are available.

CAUTION: For filling or removing portable water container used for humidity water supply use an OSHA approved ladder such as supplied by McMaster-Carr P/N 8188T88 (Ladder 48" with handrails) meets OSHA and ANSI A14.7 standards or equivalent.

ATOMIZING HUMIDITY WATER REQUIREMENTS

On a humidity system, water and air is required for the atomizing humidity system. Also, systems not utilizing a solid state humidity sensor may use a wick tank to measure wet bulb temperature for relative humidity measurements. If a wick tank is included, periodic replacement of the wet sock is required. It is recommended that the wet sock is replaced once a week or prior to a test that has a duration of more than two weeks. Systems incorporating a water demineralizer require periodic cartridge replacement determined by the quality of water you utilize. Connect humidity inlet water to the connection provided marked humidity water inlet. Water levels in the wick tank and the steam generator are controlled automatically by individual float mechanisms.

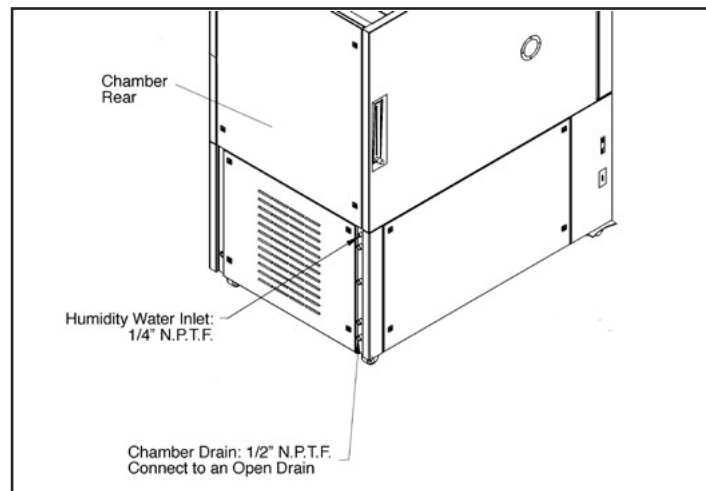

The humidity water outlet should be connected to an open drain.

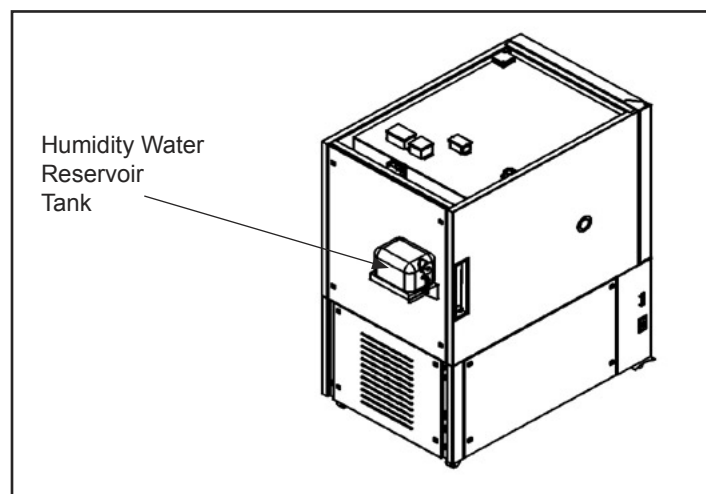

If your system utilizes a reservoir tank, the tank must be placed on top or at an elevation higher than the chamber.

CAUTION: For filling or removing portable water container used for humidity water supply use and OSHA approved ladder such as supplied by McMaster-Carr P/N 8188T88 (Ladder 48" with handrails) meets OSHA and ANSI A14.7 standards or equivalent.

ATOMIZING HUMIDITY SYSTEM

In some systems an atomizing system is used for humidity control in lieu of a traditional steam generator system. The atomizing system consists of:

Water and air regulator/filter/gauge assembly

Control solenoids

Atomizing nozzles

Mounting plate complete with all necessary plumbing

The system is controlled by the humidity output from the programmer/controller on your system. Time proportioned outputs are used to pulse/modulate the control solenoids which then introduce the atomized mist into the plenum. Water droplets are roughly the size of a dust particle, which produces the desired fogging within the chamber.

The advantages of the atomizing system over the steam generator are:

1. Less maintenance
2. Faster response
3. Better control due to the faster response
4. Easier to install
5. Less costly to operate (110 V only is required)

Humidity water quality is an important issue for the customer to consider. Humidity systems require water that is neither scale forming nor corrosive. It is recommended that humidity water should have a specific resistance in the range of 50,000 to 200,000 ohms. Water that is super pure or impure will cause problems in the system.

To accomplish this, Envirotronics recommends using a Barnstead filtration system consisting of:

- 1. B4511 Cartridge holder*
- 2. D0803 High capacity, Two-bed mixed resin, (this filter will produce 800 liters of water to a 50,000 ohm end point.)*
- 3. Optional Pura-Lite provides Go/No Go indication of water quality.*
- 4. Optional filters and holders to address specific water issues are also available.*

This system is based on using standard tap water, (drinking), in your area.

HUMIDITY SYSTEM OPERATION

Systems that incorporate humidity as an option, require the enabling of an Event or Auxiliary for humidity control. Two (2) types of controllers are listed below for *examples* on how this is accomplished.

1) Systems Plus

To operate your system in the humidity mode, Auxiliary 1 must be on. This is accomplished in one of two methods. Either as part of your program, Editor Program Screens, Item #14 (Auxiliary 1) or Manual Control Screen, Item #11.

2) Chromalox 2030

To operate your system in the humidity mode, Event #1 must be on. This is accomplished by one of two methods. Either as part of your program, instrument pages 1-16 (Event #1, Menu 41-49) of the program, or through instrument page 20 (Menu 26, set to 10 = +/- "Deviation NE" and Menu 34 set to 1 - Event output #1). **NOTE:** Events are programmed using binary numbers

Measurement of humidity can be accomplished in two (2) different methods. A Direct relative humidity (solid state) sensor like Vaisla's HMM30C or wet bulb dry bulb control.



Equipment Start-Up



Envirotronics' Equipment Start-Up is the Smart way to Start

There is no better way to get your new equipment off to a great start than to have a factory-trained expert on-site to ensure its proper performance. Protect your equipment/ investment by having the Envirotronics' field service technician personally train you in its operation.

Envirotronics provides turnkey installation of both new and used environmental test equipment. Our field service technicians are factory-trained, EPA certified, and well-experienced in the installation and start-up of your equipment. Installation and Start-up performed by our field service technicians ensures that your equipment will perform to its full potential "right-out-of-the-crate".

Envirotronics has reduced start-up prices in an effort to assure the correct operation and proper use of your equipment. We strongly recommend that you take advantage of these prices when purchasing any new test chamber.

For pricing and more information, contact Envirotronics' Customer Support Group 616-554-5022.

Here is a brief overview of our thorough start-up checklist:

Electrical System

- main disconnect
- phasing
- line and control voltage and connections
- contact points, timer settings, fuses, and grounding
- general condition of boxes, labels
- compressor head fans & crankcase heaters
- heater frames and elements

Resistance Verification (Ohms)

- compressor three-phase and single-phase applications
- heaters & steam generator elements

Current Verification (Amps)

- high stage, low stage, and trim compressors
- heaters, circulators, steam generator, condenser fan motor, and blower motor

General Items

- physical condition of chamber, insulation, and quiet package
- condition of mineralacs, RCB's, tie straps
- labels
- panels and knobs
- drip pan
- door and door latch
- interior light bulbs
- grease bearings
- belts
- fan blades and blower wheels
- gauges

Instrumentation

- reading correctly
- check configuration, Temp Sentry limits, HLS settings
- sensors
- Systems Plus™, chart recorder, humidity sensor

Please note:

Use of non-Envirotronics personnel for start-up could void your warranty.

Refrigeration

- low and high stage refrigerant charge
- low and high stage pressure switch settings
- low and high stage oil level
- capacity controls
- low and high stage frostback
- low and high stage discharge temp
- fan cycling operation
- condenser and evaporator coils
- inlet and outlet water temperature
- inlet and outlet water pressure
- water regulator
- leak check
- solenoids
- cap tubes
- oil separators
- labels
- valves
- armaxflex on bulbs
- acid test on compressor oils

Humidity

- condition of boiler & boiler hose
- water level in wick tank
- leak check boiler
- fittings for tightness
- thermostat
- demineralizer cartridge
- atomizer fittings
- condition of nozzles
- water and air pressure regulator
- dry air purge
- leaks
- solenoids
- desiccant tower transfer
- moisture indicator
- CargoCaire Drier
- wheels and belts

**Ask about our A2LA accredited Calibration Services.
Have your equipment calibrated by experts during your start-up!**

Contact our Customer Support Group

Tel: 616-554-5022 • Fax: 616-554-5024 • Email: service@envirotronics.com



Envirotronics[®]

3881 N. Greenbrooke S.E.
Grand Rapids, MI 49512

Tel (800) 368-4768 • (616) 554-5020

Fax (800) 791-7237 • (616) 554-5021

Email sales@envirotronics.com

service@envirotronics.com

Web www.envirotronics.com



START UP CHECKLIST

Not all items on this list may apply to your chamber.

If you have any questions regarding which items do or do not apply, please feel free to call Envirotronics' Product Support Group (616) 554-5022 or email service@envirotronics.com. Reference electrical installation section of manual and electrical drawings.

- Proper voltage and current has been supplied. The voltage and current have been established for your chamber at the time of purchase. It is important that the correct power requirements have been met.

Example: 208 volt is not the same as 230 volt nor are they interchangeable. Use of the incorrect voltage (208) will void your warranty.

- Chamber has been leveled. Standard floors with slight (1/4" or less) variations are acceptable.
- Humidity water and humidity drain connected and water supply turned on. *Use an OSHA approved ladder such as supplied by McMaster-Carr P/N 8188T88 (Ladder 48" with handrails) that meets OSHA and ANSI A14.7 standards or equivalent.*

- Humidity water requirement: OHM range 50,000 to 200,000

STARTING UP A CHAMBER

WARNING: You must operate the chamber to perform this procedure. Do not attempt to operate the chamber unless you have read the instructions.

WARNING: Do not start up the chamber until all the other installation procedures are complete. Make sure the chamber is completely assembled according to your engineering drawings.

START UP PROCEDURE

Before proceeding with this section, verify that all steps on the Start-up Checklist have been completed.

- 1.) Turn function switch(es) to the off position.
- 2.) Turn on main power to chamber.
- 3.) Verify incoming voltage and control circuit voltage (110 volt) between X1 and X2.
- 4.) Set temperature safety device if applicable to desired temperature.
- 5.) The refrigeration system has been pumped down for shipment. Backseat all valves with yellow tags. (If applicable to your chamber.)
- 6.) Familiarize yourself with the controller which should be powered up at this time.
- 7.) Turn the function switch to the on position.
- 8.) This will enable the circulator contactor and the circulator will run.
- 9.) Check rotation of circulator motor. Direction should be indicated on the motor. (3 phase system only.)
- 10.) The setpoint value in the controller will enable the heating and cooling as required.

NOTE: Chambers employing an Envirotronics' Systems Plus™ Programmer/Controller require starting of the Systems Plus prior to turning on functions switches. Press 'start' key, select 'start system'...Enter. You can download the Systems Plus™ or Solutions Plus™ Manual on our Website www.envirotronics.com.

WARNING: You must operate the chamber to perform this procedure. Do not attempt to operate the chamber unless you have read the instructions.

WARNING: Do not start up the chamber until all the other installation procedures are complete. Make sure the chamber is completely assembled according to your engineering drawings.

SYSTEM OPERATION

OPERATION SAFETY INSTRUCTIONS

Follow all **WARNINGS** to prevent personal injury and death.

- WARNING:** To safely operate the chamber, you must read the General Safety Instructions and all the instructions in this manual.
- WARNING:** Avoid exposing yourself to air and equipment that is not near room temperature. Port gloves are not designed to insulate your hands.
- WARNING:** Using gloves left in a chamber when the temperature is lower than 0 °C (32 °F) or higher than 37.8 °C (100 °F) could cause frostbite or burn your hands.
- WARNING:** Use your chamber only for testing the products it was designed to test. Do not put combustible or explosive materials in the chamber.
- WARNING:** Keep the chamber door closed while the chamber is operating.
- WARNING:** Breathing gas from the GN₂ (gaseous nitrogen), LN₂ (liquid nitrogen) system can cause death from suffocation. Dilute the air before entering the chamber.

Follow all **CAUTIONS** to prevent equipment damage.

- CAUTION:** Do not operate the chamber beyond the specifications.
- CAUTION:** To protect from temperatures that are too high or too low, you must use a protection device. Product protection is your responsibility.

*Before proceeding with this section, be sure that the **Start-up Checklist** and the **Start-up Procedure** have been completed. The Start-up Checklist and Start-up Procedure are completed initially when the chamber is installed and need not be repeated.*

1. Turn the master switch to the “on” position. This will enable the remaining switches to be functional by providing control circuit power.

The light switch, when applicable, enables the chamber compartment light.

SYSTEM OPERATION (Continued)

2. Turn the circulator switch to the “on” position. This not only enables the circulator motor, but also provides control circuitry power to the heat and cooling switches. If the circulator does not run, refer to the Troubleshooting Guide.

3. Turn the heat switch and cool switch to the “on” positions. This will enable the controller to output accordingly with the set point entered. For operating the chamber hot or cold, both switches should be in the on position to achieve the desired setpoint. If the circulator is turned on and the heat and cool switches are off, the chamber temperature will rise above the ambient due to the fan rotation working on the air. The friction of the fan blade on the air will create the heat that is displayed on your controller.

4. If applicable, turn the humidity switch on when operating the chamber in a temperature/humidity mode. A temperature/humidity mode is when both the dry bulb (sensible temperature) and humidity level at that temperature are being controlled simultaneously. The humidity mode switch is typically a manual-off-auto. The position selected is determined by the test you are running. If humidity control is not desired, place the switch in the off position. If you are operating the chamber continuously in a temperature/humidity mode either through the controller key pad or via automatic programmed control, place the switch in the manual position. If you are operating the chamber via programmed control only and your test requires you to change from a temperature only mode to a temperature/humidity mode, then place the switch in the auto position and activate Event #1 (or Aux#1 depending on the type of control instrument) of your program to automatically switch the system from temperature to temperature/humidity modes.

Example: Event #1 on (temperature/humidity mode)
 Event #1 off (temperature mode)

Every chamber is designed with specific limitations for operating the humidity system. Please refer to the chamber specifications serial tag for maximum dry bulb temperature and minimum dewpoint temperature.



Instrument Calibrations

Instrument Calibrations

In order for your environmental test equipment to perform repeatable accurate tests, your instrumentation must be calibrated. Envirotronics is accredited for technical competence in the field of calibration and can provide the latest ISO/IEC 17025 (A2LA accredited) calibration services at your facility. Our field service technicians are highly trained and qualified to perform your instrument calibrations with reliability and confidence.



Automotive Suppliers



Envirotronics is pleased to help make the task of compliance with the QS9000 3rd Edition Calibration Mandate much simpler. There is no need for you to take the time to actively seek an accredited laboratory. Envirotronics, certified ISO9001 in 1997, can provide the latest required ISO/IEC 17025 (A2LA accredited) calibration services at your facility. These services meet 17025 requirements and ensure that your company is in compliance with the most recent changes in the QS9000 3rd Edition mandate.

Please contact us for a copy of our Certificate of Accreditation and a copy of our Calibration Scope of Accreditation. You may also visit our website at <http://www.envirotronics.com/a2laced.html> to download and print a copy of these important documents to keep on file.

From the cost-saving Value Plus Program to preventive maintenance, emergency service and now A2LA accredited instrument calibrations, Envirotronics is the single-source supplier for all of your environmental test equipment needs. Take this opportunity to experience our top-notch customer service and begin a long lasting partnership with us.

Contact our Customer Support Group for a quote on your instrument calibration needs.

Tel: 616-554-5022

Fax: 616-554-5024

Email: service@envirotronics.com



ISO/IEC 17025 COMPLIANCE

...made easy

According to the QS9000 3rd Edition Calibration Mandate, all instrument calibrations must be performed and certified by an accredited calibration laboratory. And now...the deadline for compliance with this mandate is already here!

At Envirotronics, we are pleased to make the task of compliance with this mandate much easier. There is no longer any need for you to actively seek an accredited laboratory. Envirotronics is proud to announce the receipt of A2LA accreditation for technical competence in the field of calibration.

Envirotronics can now provide the latest ISO/IEC 17025 (A2LA accredited) calibration services at your facility!

These services meet 17025 requirements and ensure that your company is in compliance with the most recent changes in the QS9000 3rd Edition mandate.

Our national network of field service technicians is highly trained and qualified to perform your instrument calibrations with reliability and confidence. From new and used equipment, preventive maintenance, and equipment modifications to equipment relocation,

spare parts, and now A2LA accredited instrument calibrations, Envirotronics is the single-source-supplier for all of your test equipment needs.

Please contact us for a copy of our Certificate of Accreditation and a copy of our Calibration Scope of Accreditation. Call our Customer Support Group and schedule your instrument calibration today!

Need more info?

Call **616-554-5022** or visit our website **www.envirotronics.com** to learn more about Envirotronics Equipment and Service.

For A2LA Accredited Instrument Calibrations performed at your facility, call 800-368-4768 today!



7/01



Registered ISO 9001 • A2LA Accredited Calibration Services • Locations Nationwide
www.envirotronics.com • 800-368-4768 • 616-554-5022 • Fax 616-554-5024



Fill out the attached card and send it in to Envirotronics Calibration Services and we will contact you to schedule your next instrument calibration appointment.

PLEASE CONTACT ME ABOUT INSTRUMENT CALIBRATIONS!

Name _____ Title _____
Company _____ Division _____
Address _____
City _____ State _____ Zip _____
Tel _____ Fax _____
Email _____

How many instruments will require calibration? _____

What types of instruments will require calibration? _____

Who currently performs service on your environmental test equipment? _____

What industry magazines do you read? _____

What industry trade shows do you attend? _____

Would you like to receive information on our full line of environmental test chambers and equipment? _____

Fill out, cut out, and return to:

Envirotronics Calibration Service
3881 N. Greenbrooke SE
Grand Rapids, MI 49512

OR

CALL 1-800-368-4768

**WARNING: RISK OF ELECTRICAL SHOCK. DISCONNECT POWER BEFORE SERVICING UNIT.
USE LOCK-OUT/TAG-OUT PROCEDURES.**

TROUBLESHOOTING

Even though your system has been designed to provide years of trouble-free service, mechanical problems may occur. The following has been provided to assist the operator or maintenance department in finding problems. If the problem cannot be corrected after these checks are made, contact the Envirotronics' Product Support Group.

**Envirotronics Product Support Group: 1-800-368-4768
616-554-5022**

The Troubleshooting Guide is set up in the following manner:

- The Roman numerals denote the problems. (I, II, III, IV, etc.)
- The capital letters denote the possible causes. (A, B, C, D, etc.)
- The numbers denote the solutions. (1, 2, 3, 4, etc.)

WARNING: Dangerously high voltages are present. Do not turn on the electrical power until you are instructed to do so in the start -up procedure.

WARNING: Disconnect the electrical power before working near moving parts. Keep all guards and shields in place.

TROUBLESHOOTING GUIDE

I. No displays on instruments no indicator lights on panel

A. No incoming power

1. Verify power source problem and reestablish main power.

B. Transformer Secondary fuse blown

1. Find the reason for the trip.
2. Make necessary repairs.
3. Replace fuse.

C. Defective Transformer

1. Verify transformer has incoming power.
2. Replace transformer.

D. Loose terminals on control circuit

1. With main power off, tighten all electrical terminals.

E. Controller Defective

1. Verify power on incoming side to controller.
2. Consult factory.

II. Circulator will not run

A. Power is not present

1. Master switch is in on position.
2. Is power passing through switch?

B. Defective motor

1. Verify wiring and voltage to motor.
2. Replace motor.

III. Chamber will not heat

A. Circulator not running

1. Verify circulator is running. If not, use Section II for troubleshooting.

WARNING: Dangerously high voltages are present. Do not turn on the electrical power until you are instructed to do so in the start -up procedure.

WARNING: Disconnect the electrical power before working near moving parts. Keep all guards and shields in place. Use Lock-Out / Tag-Out Procedures.

TROUBLESHOOTING GUIDE (Continued)

III. Chamber will not heat (Continued)

B. Heat relay defective

1. Verify high voltage to relay, if absent check fuse.
2. Verify control voltage to relay, if absent check controller output.

C. Controller not outputting

1. Verify controller is in heat demand. Refer to controller manual.

D. Heat links blown

1. Check resistance (power off) of all heating elements to verify heat link continuity.

Note: The resistance value will not be ("0").

IV. Chamber not cooling properly

A. Circulator not running

1. Verify circulator is running. If not, use Section II for Troubleshooting.

B. Cooling contactor(s) defective

1. Verify power to contactor(s).
2. Check incoming power. If present, check fuse(s).
3. Check outgoing power. If absent, replace compressor contactors.
4. Check control voltage to contactor. If absent, refer to controller.

C. Controller not outputting

1. Verify controller is in a cool demand. Refer to controller manual.

D. Reset all pressure switches on compressor(s)

E. Compressor defective

1. Consult factory after above items have been checked.

WARNING: Dangerously high voltages are present. Do not turn on the electrical power until you are instructed to do so in the start -up procedure.

WARNING: Disconnect the electrical power before working near moving parts. Keep all guards and shields in place. Use Lock-Out / Tag-Out Procedures.



Preventive Maintenance Program



Preventive Maintenance Program

Your environmental test equipment can only be of value to you if it is in good running condition. Utilizing Envirotronics' Preventive Maintenance Program affords you the assurance that your test equipment will be ready to perform to specification when you need it - day after day, year after year.

Envirotronics' Preventive Maintenance Program consists of a minimum of two visits per year, per system by one of our factory-trained field service technicians. During each visit, all electrical components, refrigeration components, and other equipment and systems will be thoroughly inspected. Where possible, routine minor adjustments will be made to return your equipment to top running condition as a part of this service. Upon completion of the inspection, our service technician will provide you with a detailed recommendation of any additional repairs that may be needed.

An additional benefit of the Envirotronics Preventive Maintenance Program is that it is not limited to only Envirotronics-manufactured equipment. In fact, this indispensable program is **available for most makes and models of environmental test chambers!**

Here is a brief overview of our thorough systems and components checklist:

Electrical System

- main disconnect
- phasing
- line and control voltage and connections
- contact points, timer settings, fuses, and grounding
- general condition of boxes, labels
- compressor head fans & crankcase heaters
- heater frames and elements

Resistance Verification (Ohms)

- compressor three-phase and single-phase applications
- heaters & steam generator elements

Current Verification (Amps)

- high stage, low stage, and trim compressors
- heaters, circulators, steam generator, condenser fan motor, and blower motor

General Items

- condition of chamber, insulation, and quiet package
- condition of mineralacs, RCB's, tie straps
- labels
- panels and knobs
- drip pan
- door and door latch
- interior light bulbs
- grease bearings
- belts
- fan blades and blower wheels
- gauges

Instrumentation

- reading correctly
- check configuration, Temp Sentry limits, HLS settings
- sensors
- Systems Plus™, chart recorder, humidity sensor

Refrigeration

- low and high stage refrigerant charge
- low and high stage pressure switch settings
- low and high stage oil level
- capacity controls
- low and high stage frostback
- low and high stage discharge temp
- fan cycling operation
- condenser and evaporator coils
- inlet and outlet water temperature
- inlet and outlet water pressure
- water regulator
- leak check
- solenoids
- cap tubes
- oil separators
- labels
- valves
- armaflex on bulbs
- acid test on compressor oils

Humidity

- condition of boiler & boiler hose
- water level in wick tank
- leak check boiler
- fittings for tightness
- thermostat
- demineralizer cartridge
- atomizer fittings
- condition of nozzles
- water and air pressure regulator
- dry air purge
- leaks
- solenoids
- desiccant tower transfer
- moisture indicator
- CargoCaire Drier
- wheels and belts

The cost of your Preventive Maintenance Program will depend on the size and type of your system and the desired frequency of inspection.

Contact our Customer Support Group for a quote on a Preventive Maintenance Program for your equipment today.

Tel: 616-554-5022 • Fax: 616-554-5024 • Email: service@envirotronics.com



Envirotronics™

3881 N. Greenbrooke S.E.
Grand Rapids, MI 49512

Tel (800) 368-4768 • (616) 554-5020

Fax (800) 791-7237 • (616) 554-5021

Email sales@envirotronics.com
service@envirotronics.com

Web www.envirotronics.com



PREVENTIVE MAINTENANCE

Since an environmental chamber is a sophisticated piece of test equipment, continuous monitoring of the system will minimize downtime due to mechanical malfunctions.

A good preventive maintenance program will assure that the major components are maintained properly and the system will give many years of uninterrupted service. Envirotronics does offer a Preventive Maintenance Contract, which can be purchased from Envirotronics' Product Support Group.

This contract was designed to cover not only the major system components, but also the general condition of your equipment. Some standard components require periodic replacement. Failure to replace these components may cause system downtime. For additional information, please contact our Product Support Group.

**Envirotronics Product Support Group: 1-800-368-4768
616-554-5022**

NOTE: Envirotronics provides service and parts for all makes and models of environmental test equipment.

WARNING: Dangerously high voltages are present. Do not turn on the electrical power until you are instructed to do so in the start -up procedure.

WARNING: Disconnect the electrical power before working near moving parts. Keep all guards and shields in place. Use Lock- Out / Tag-Out Procedures.

SCHEDULED PREVENTIVE MAINTENANCE INTERVALS

Inspect	Daily	Weekly	Monthly	Quarterly	Semi-Annually	Annually	Procedure No.
High Stage Charge		●					1
Low Stage Stand-By		●					2
Compressor Oil Level*		●					3
Circulator Motor			●	●			4
Electrical Panel				●			5
Operating Currents				●			6
Tubing Abrasion				●			7
Humidity Sensor Rotronics			●				8
Atomizing Nozzle /Humidity system			●				9
Chamber			●				10
Wet Socks (If applicable)		●					11
Condenser						●	12

* *Dark Compressor Oils (Perform oil flush on an as needed basis, typically when oil levels cannot be determined). Removal of oil sight glass for cleaning may be required.*

Note: *On the following Preventive Maintenance Pages, you will find a brief description of the above routine checks.*

PREVENTIVE MAINTENANCE PROCEDURES

Procedure No. 1: HIGH STAGE CHARGE



Observe the sightglass to see if there are any bubbles. This should be checked during pull down after at least 2 minutes of operation. Bubbles indicate a lack of refrigerant. If bubbles are seen during bypass operation, this does not indicate a gas shortage. Also, observe the color of the moisture indicator in the sightglass.

Green is dry
Yellow-green (chart reuse) is caution
Yellow indicates moisture.

Procedure No. 2: LOW STAGE STAND-BY

The stand-by may be read on the low stage discharge gauge prior to the day's operation if the equipment has been turned off overnight.

If the equipment has been running, the chamber (and cascade section) must be at ambient temperature and equalized to read the stand-by pressure.

Procedure No. 3: COMPRESSOR OIL LEVEL



With compressor(s) running, the oil levels should be maintained between 1/8 to 3/8 on the sightglass. Oil leakage should not be tolerated. Any deviation from the normal oil level should be investigated immediately.

Procedure No. 4: CIRCULATOR MOTORS

Check the rotation of the fan/blower (suction at the grill) and check the fan/blower for tightness on the motor, shaft/jack shaft assembly. If your equipment has a jack shaft assembly, the bearings require lubrication once a month using *Dow Corning BR2-Plus* or a grease conforming to *NLGI grade #2*.

PREVENTIVE MAINTENANCE PROCEDURES (Continued)

Procedure No. 5: ELECTRICAL PANEL

Check for components and wires that may vibrate loose during operation. Check for signs of contactor or relay arcing. Check to see the power and ground connections remain secure.

Procedure No. 6: OPERATING CURRENTS

With an amprobe, check the operating current of the compressors, heaters, circulator and other components. These components are shown on the electrical schematic.

Procedure No. 7: TUBING ABRASION

Check for evidence of friction wear on all refrigeration lines. Particular care should be taken on inspecting capillary tubes to pressure switches and gauges.

Procedure No. 8: HUMIDITY SENSOR

Clean dust filter. Cleaning should be done without removing the filter from the probe. Gently wipe the filter with a solution of water and mild detergent.

NOTE: If this does not remove most of the stains, the filter should be replaced.

Procedure No. 9: ATOMIZING NOZZLES

Make sure nozzles are clean and free of obstructions.

Procedure No. 10: CHAMBER

Clean interior of chamber with a stainless steel cleaner and inspect overall condition of box. If your chamber has windows, clean with a glass cleaner.

Procedure No. 11: WETSOCKS

Check wetsock for replacement weekly or every time a humidity test is begun. (If applicable to your chamber.)

Procedure No. 12: CONDENSER

Clean condenser as required by flushing or rodding as needed. Typically when discharge pressures are higher than normal.

NOTE: This is a preventive maintenance list. You may add or delete items as your in house system requires.

DECONTAMINATION AND DECOMMISSIONING, AND LOCK OUT / TAG OUT PROCEDURE

From time to time it may become necessary to either replace or scrap out the test chamber. When this occurs, please consider the following information.

1. Check with your plant assets manager to see if equipment is leased or owned.
2. Check with your Envirotronics sales contact. Envirotronics has a program to purchase your used test chamber. Otherwise, contact local or regional used equipment buyers.
3. **Lock Out / Tag Out Procedure:**
 - a. Turn off disconnect for chamber, located on wall adjacent to the chamber.
 - b. Using a multimeter, verify incoming power is off at terminals.
 - c. Turn off air supply and lock out.
 - d. Turn off water supply. Approximately 6 gallons (22.8 liters) in system.
 - e. Check your company's LOTO procedures for additional instructions for your location.
4. Reclaim refrigerant. Approximately 5 - 6# of R404A (HP62) in system.
Please note: This should be accomplished by a trained refrigeration technician in compliance with state, federal and county requirements. Or, call the Envirotronics Customer Support Group:

**Envirotronics Product Support Group: 1-800-368-4768
616-554-5022**

5. Remove oil (RL32CF) from compressor. There should be approximately 1/2 gallon (1.9 liters) in the system.
Please note: This should be accomplished by a trained refrigeration technician in compliance with state, federal and county requirements. Or, call the Envirotronics Customer Support Group (number listed above).
6. Remove water from Humidity system. There is approximately 6 gallons (22.8 liters) of water in the humidity system.

CAUTION: When removing water from the humidity system, use an OSHA approved ladder such as supplied by McMaster-Carr P/N 8188T88 (Ladder 48" with handrails) meets OSHA and ANSI A14.7 standards or equivalent.

DECONTAMINATION AND DECOMMISSIONING, AND LOCK OUT / TAG OUT PROCEDURE (Continued)

7. Disconnect air line slowly to allow air to bleed out of the system.

CAUTION: When disconnecting air line, use an OSHA approved ladder such as supplied by McMaster-Carr P/N 8188T88 (Ladder 48" with handrails) meets OSHA and ANSI A14.7 standards or equivalent.

8. Use hand valve to release pressure in chamber to allow door to open (Altitude chambers only).

WARNING: Before service or repair allow chamber to cool to ambient room temperature before entry.

After performing the above listed steps, your chamber should be ready to place on a skid and secure for shipment.



Spare & Replacement Parts

Spare and Replacement Parts

Envirotronics is the one-stop shop for all your environmental test equipment parts needs. From small components and materials to sub-assemblies and systems, Envirotronics provides replacement and spare parts for most makes and models of environmental test equipment. To help eliminate confusion, our parts are identified by the Envirotronics part number **and** the original manufacturer's part number. This makes cross referencing and location of parts quick and easy. We are committed to your success.

All quotations for new Envirotronics equipment include an option for spare parts. We urge you to maintain a limited inventory of spare parts at your facility. Although our service vehicles are well equipped with many system components, there are occasions when unique parts are not readily available. Maintaining a small inventory of unique spare parts can dramatically reduce the downtime of your equipment.

Remember, owning an Envirotronics-made chamber is not a requirement to take advantage of this convenient and time-saving service. We stock parts for most makes and models. If we don't have your special part in stock, we will find it for you. There is no reason to spend your time hunting down replacement parts. Let us do the work for you!

Our friendly and knowledgeable customer support personnel are ready to help you. They have the resources and the experience to answer your questions and handle your parts order quickly and efficiently. Orders for stock parts that are received by 2:00 pm EST will be shipped the same day. We will ship via the carrier you designate, and overnight and Saturday delivery is available upon request.

Our Value Plus™ customers will enjoy an automatic 10% discount on all parts and materials and, in addition, will receive next day delivery of all parts in stock if ordered by 2:00 pm EST. To learn more about our Value Plus™ Program give us a call or visit our website at www.envirotronics.com.



We have what it takes to keep your environmental test equipment running as it should. From parts and service to technical expertise and money-saving programs, Envirotronics is the one-stop shop for all of your environmental test equipment needs. Give us a call today to find out how we can help you. We want to be your chamber company.

Terms and Conditions

1. All orders must be accompanied by a written P.O.
2. Payment Terms are net 15 days A.R.O.
3. All price quotes for parts and materials are valid for 45 days.
4. The 10% discount will apply to Value Plus™ customers with a current contract only. No other cash discount will apply.
5. Most standard parts are in stock at Envirotronics' headquarters in Grand Rapids, Michigan, and if ordered prior to 2:00 pm EST, can be shipped the same day. Standard parts orders for our Value Plus™ customers, if ordered prior to 2:00 pm EST, can be delivered the following day. Shipping is F.O.B. our dock.

Contact our Customer Support Group

Tel: 616-554-5022

Fax: 616-554-5024

Email: service@envirotronics.com



Envirotronics™

3881 N. Greenbrooke S.E.
Grand Rapids, MI 49512

Tel (800) 368-4768 • (616) 554-5020

Fax (800) 791-7237 • (616) 554-5021

Email sales@envirotronics.com

service@envirotronics.com

Web www.envirotronics.com



RECOMMENDED SPARE PARTS

If a day or two of downtime does not present a problem for you to accomplish your testing requirements, read no further.

It is highly recommended that our customers maintain a minimum quantity of spare parts for emergency situations. Envirotronics maintains a complete inventory of spare parts at our main plant and each field service vehicle is stocked with frequently used parts and materials. However, there are occasions when certain parts are not readily available. Whether your chamber is under warranty or not, a “Spare Parts Package” can save you money.

- First, you save shipping costs.
- Second, you assure expedient repairs and minimize downtime.
- Third, you receive discounted prices if you purchase the package.

Please contact our Product Support Group if you have any questions or would like a quotation for a Recommended Spare Parts Package.

**Envirotronics Product Support Group: 1-800-368-4768
616-554-5022**



Envirotronics®

Value Plus™ Special Service Program

Value Plus Special Service Program

Envirotronics' Value Plus Program is an all-inclusive pre-paid service agreement to be used for emergency service, refrigeration retrofits, calibrations, preventive maintenance, equipment relocation, instrument upgrades, equipment startups, installations, parts, and materials. In addition, the Value Plus Program offers many additional valuable cost-saving benefits. The program is available in blocks of \$4,000 and multiple blocks are available. Our Value Plus Customers enjoy the full benefit of this program until the total investment is exhausted.

Become an Envirotronics "Value Plus Customer" and enjoy the following benefits...

- Labor rate **15% off** the normal local labor rate
- Travel time: **25% off** current service rate
- Mileage: **No charge**
- **10% discount** on all parts and materials
- **20% discount** on selected instrument calibrations
- **No overtime charges** Monday through Friday
- **Next day delivery** of all parts in stock if ordered by 2:00 PM Eastern Standard Time.
- **No expiration date**

Total Price is \$4,000 per Block
**Contact our Customer Support Group
to become a Value Plus Customer!**



Terms and Conditions

1. The contract amount can be utilized for any type of service required, including emergency service, preventive maintenance, travel, parts, materials, calibrations, training, or any other service necessary.
2. Travel time: 25% off current service rate
3. Mileage: No charge
4. The 10% discount will apply to all parts and materials.
5. Technical support is available through the headquarters in Grand Rapids, MI between 8:00 AM and 4:30 PM Monday through Friday.
6. The 20% discount for calibrations is good for most instruments (some sensors are not included).
7. Overtime charges under this contract (weekends only) apply to Saturdays, Sundays, and Holidays. Saturdays will be time and one half. Sundays will be double time, and Holidays will be double time and one half. Weekend and Holiday rates are based on regular rates, not reduced rates.
8. Most standard parts are in stock at Envirotronics' headquarters in Grand Rapids, MI, and if ordered prior to 2:00 PM E.S.T., can be delivered the following day. Shipping is F.O.B. our dock.
9. This contract is valid until the total investment is exhausted.
10. Payment terms are net 15 days A.R.O. for the entire value of the contract. (Invoiced immediately upon receipt of P.O.).
11. Airfares, car rentals are billed at cost.

* Prices are based on current rates and are subject to change. The above discounts are based on prepayment of the Value Plus invoice. Work performed prior to receipt of payment are billed at standard rates.

Travel time is based on portal to portal.

Envirotronics®



3881 N. Greenbrooke S.E.
Grand Rapids, MI 49512
Tel (800) 368-4768 • (616) 554-5020
Fax (800) 791-7237 • (616) 554-5021
Email sales@envirotronics.com
service@envirotronics.com
Web www.envirotronics.com



Quality System
Registered to
ISO 9001

Certificate No. 1276-01

**Material
Safety
Data
Sheets**



Envirotronics®

5644



MATERIAL SAFETY DATA SHEET

BVA SOLEST SERIES

SECTION I: General Information

Manufacturer/Supplier Name:	Phone :	248-348-4920
BVA OILS	Emergency :	CHEMTRAC
48845 West Road		1-800-424-9300
Wixom, Mi 48393-6042	Date prepared:	09/08/97

SECTION II: COMPONENT INFORMATION

Chemical Name	CAS REG NO.	PERCENTAGE (%)
Ester (Polyol Ester)	Proprietary	99 +
Alkylated Phenol & Benzotriazole	Proprietary	< 1

SECTION III: POTENTIAL HEALTH EFFECTS FROM OVEREXPOSURE

EYE : May cause eye irritation.

INHALATION : If sprayed or misted may cause chemical pneumonitis. Product is not toxic by inhalation.

INGESTION : Do Not Take Internally. Low toxicity on ingestion, may cause nausea and diarrhea.

SKIN : Minimally irritating. Prolonged contact can cause dermatitis.

To the best of our knowledge, the toxicological properties of these compounds have not been fully investigated. Analogous compounds are considered to be essentially non-toxic

SECTION IV: FIRST AID PROCEDURES

EYE : Copious warm water flush-15 minutes. Consult a physician if irritation.

SKIN: Remove contaminated clothing-Launder or dry clean clothes before reuse. Dispose of leather articles.

INHALATION : Evacuate to a safe area with plenty of fresh air. Allow victim to rest in a well ventilated area then seek medical aid immediately.

INGESTION : DO NOT induce vomiting. Force fluids. Activate charcoal tablets.

SECTION V: FIRE FIGHTING PROCEDURES

This product is: Combustible			
FLASH POINT °C= OPEN CLEVELAND OPEN CUP	230-300	LOWER EXPLOSIVE LIMIT	NOT APPLICABLE
UNUSUAL HAZARDS : Burning fluid may evolve irritating/noxious fumes.			

EXTINGUISHING AGENTS :	Dry chemical, CO foam, water fog.
PROTECTIVE CLOTHING :	Fire-fighters should use NIOSH/MNSA approved self-contained breathing apparatus and full protective gear.
FIRE-FIGHTING PROCEDURES :	Use water fog to cool fire exposed containers. USE WATER CAREFULLY NEAR EXPOSED/BURNING LIQUIDS. May cause frothing and splashing of hot material.

SECTION VI: SPILL OR LEAK HANDLING PROCEDURES

PERSONAL PROTECTION :	Wear protective clothing including splash proof goggles, rubber gloves and rubber overshoes. Remove all contaminated clothing promptly.
PROCEDURES :	Floor may be slippery: use care to avoid falling. Contain spill immediately with inert material (e.g. sand, earth). Transfer liquids and solid diking material to separate suitable containers for recovery or disposal.
CAUTION: Keep spills and cleaning runoff out of municipal sewers and open bodies of water.	

SECTION VII: HANDLING AND STORAGE

Avoid contact with eyes, skin and clothing.

Ensure that containers are properly secured before moving.

Keep container closed and keep away from oxidizing materials.

Store in a cool-well ventilated area. Product is hygroscopic. Storage under Nitrogen is highly recommended.

"Empty" containers retain residue (liquid and/or vapor) and can be dangerous. DO NOT PRESSURIZE, CUT, WELD, BRAZE, SOLDER, DRILL, GRIND OR EXPOSE SUCH CONTAINERS TO HEAT, FLAME, SPARKS, STATIC ELECTRICITY, OR OTHER SOURCES OF IGNITION; THEY MAY EXPLODE AND CAUSE INJURY OR DEATH. Do not attempt to clean since residue is difficult to remove. "Empty" drums should be completely drained, properly bunged and promptly returned to a drum reconditioner. All other containers should be disposed of in an environmentally safe manner and in accordance with governmental regulations. For work on tanks refer to Occupational Safety and Health Administration regulations, ANSI Z49.1, and other governmental and industrial references pertaining to cleaning, repairing, welding, or other contemplated operations.

SECTION VIII: COMPONENT EXPOSURE LIMITS & PERSONAL PROTECTION

COMPONENT EXPOSURE LIMIT		OSHA		ACGIH		CARCINOGENIC
COMPONENT	UNITS	TWA	STEL	TLV	STEL	
Ester (Polyol Ester)	mg/m ³	N.D.	N.D.	N.D.	N.D.	No
Alkylated Phenol & Benzotriazole	mg/m ³	N.D.	N.D.	N.D.	N.D.	No

PERSONAL PROTECTION MEASURES

EYE	Safety glasses (ANSI Z87.1) or approved equivalent.
SKIN	Strongly recommend protective gloves, especially for prolonged exposures. Gloves should be removed immediately if there is any indication of degradation or chemical breakthrough. Long sleeved clothing to minimize skin contact.
INHALATION	Use in well ventilated area. If mist is being generated and exceeds the TWA/TLV listed above than a respiratory program meeting OSHA 1910.134 and ANSI Z88.2 requirements must be followed.

SECTION IX: PHYSICAL & CHEMICAL PROPERTIES			
APPEARANCE	Clear	SPECIFIC GRAVITY (WATER=1)	0.94-0.97
PHYSICAL STATE	LIQUID	FLASH POINT ° COC	230-300°C
COLOR	Gray to yellow or light brown tint	FIRE POINT	N.D.
ODOR	mild distinct	VISCOSITY SUS	100-2400
VAPOR PRESSURE	0.01mm of Hg (@ 20C)	MELTING POINT(POUR POINT)	0
VAPOR DENSITY (AIR=1)	NOT APPLICABLE	SOLUBILITY IN WATER	Insoluble in cold water

SECTION X: STABILITY & REACTIVITY	
STABILITY:	Stable.
CONDITIONS TO AVOID:	Excessive heat, formation of oil mist.
MATERIAL TO AVOID:	Strong oxidizers, caustic or acidic solutions such as liquid chlorine, concentrated oxygen, sodium hypochlorite, calcium hypochlorite, smoke on combustion, COx, etc.
HAZARDOUS DECOMPOSITION:	Analogous compounds evolve carbon monoxide, carbon dioxide, and other unidentified fragments when burned. See Section 5.
HAZARDOUS POLYMERIZATION:	Will not occur.

SECTION XI: TOXICOLOGICAL INFORMATION	
Toxicity data for a similar material is listed below	
Skin irritation	May cause irritation and possible dermatitis.
Eye Irritation	Slight irritation.

SECTION XII: WASTE DISPOSAL
Incinerate this product and all associated wastes in a licensed facility in accordance with Federal, State, and local regulations.

SECTION XIV: REGULATORY INFORMATION				
Degree of Hazard	NFPA	HMIS	HAZARD RATINGS	
Health	0	0	0	Insignificant
Fire	1	1	1	Moderate
Reactivity	0	0	2	High
Specific Hazards	None		3	Extreme
Personal Protection Index		B	4	Extreme

SECTION XIV: Transport Information

This product is non-hazardous. The product contains no known carcinogens. No special warning labels are required under OSHA 29CFR 1910.1200. OSHA hazard warning are not applicable for this product. Therefore no OSHA Warnings would appear on the label. No EPA hazard classification code.

THE INFORMATION IN THIS MATERIAL SAFETY DATA SHEET SHOULD BE PROVIDED TO ALL WHO USE, HANDLE, STORE, TRANSPORT OR ARE OTHERWISE EXPOSED TO THIS PRODUCT. WE BELIEVE THE INFORMATION IN THIS DOCUMENT TO BE RELIABLE AND UP TO DATE AS OF THE DATE OF PUBLICATION, BUT MAKE NO GUARANTEE THAT IT IS.



The MSDS format adheres to the standards and regulatory requirements of the United States and may not meet regulatory requirements in other countries.

DuPont
Material Safety Data Sheet

Page 1

"FREON" 23
2025FR Revised 4-NOV-2002

CHEMICAL PRODUCT/COMPANY IDENTIFICATION

Material Identification

"FREON" is a registered trademark of DuPont.

Corporate MSDS Number : DU001064
CAS Number : 75-46-7
Formula : CHF3
CAS Name : Trifluoromethane

Tradenames and Synonyms

CC0914

Company Identification

MANUFACTURER/DISTRIBUTOR
DuPont Fluoroproducts
1007 Market Street
Wilmington, DE 19898

PHONE NUMBERS

Product Information : 1-800-441-7515 (outside the U.S.
302-774-1000)
Transport Emergency : CHEMTREC 1-800-424-9300(outside U.S.
703-527-3887)
Medical Emergency : 1-800-441-3637 (outside the U.S.
302-774-1000)

COMPOSITION/INFORMATION ON INGREDIENTS

Components

Material	CAS Number	%
METHANE, TRIFLUORO-	75-46-7	100

HAZARDS IDENTIFICATION

Potential Health Effects

Inhalation of high concentrations of vapor is harmful and may cause heart irregularities, unconsciousness, or death. Intentional misuse or deliberate inhalation may cause death without warning. Vapor reduces oxygen available for breathing and is heavier than air. Liquid contact can cause frostbite.

HUMAN HEALTH EFFECTS:

(HAZARDS IDENTIFICATION - Continued)

Overexposure by inhalation may include nonspecific discomfort such as nausea, headache, or weakness; temporary nervous system depression with anesthetic effects such as dizziness, headache, confusion, incoordination, and loss of consciousness; or with gross overexposure (>20%), possibly temporary alteration of the heart's electrical activity with irregular pulse, palpitations, or inadequate circulation.

Individuals with preexisting diseases of the central nervous or cardiovascular system may have increased susceptibility to the toxicity of excessive exposures. Eye or skin contact with the liquid may cause frostbite.

Carcinogenicity Information

None of the components present in this material at concentrations equal to or greater than 0.1% are listed by IARC, NTP, OSHA or ACGIH as a carcinogen.

FIRST AID MEASURES

First Aid

INHALATION

Immediately remove to fresh air. Keep person calm. Call a physician. If not breathing, give artificial respiration. If breathing is difficult, give oxygen.

SKIN CONTACT

Flush with water. Treat for frostbite if necessary by gently warming affected areas.

EYE CONTACT

In case of liquid contact, immediately flush eyes with plenty of water for 15 minutes. Call a physician.

INGESTION

Ingestion is not considered a potential route of exposure.

Notes to Physicians

Because of possible disturbances of cardiac rhythm, catecholamine drugs, such as epinephrine, should be considered only as a last resort in life-threatening emergencies.

FIRE FIGHTING MEASURES

Flammable Properties

Flash Point: No flash point

Flammable Limits in air, % by Volume:

LEL : None per ASTM E681

UEL : None per ASTM E681

Autoignition: Not determined

Fire and Explosion Hazards:

Containers may rupture under fire conditions. Decomposition may occur.

Contact of welding or soldering torch flame with high concentrations of refrigerant can result in visible changes in the size and color of torch flames. This flame effect will only occur in concentrations of product well above the recommended exposure limits, therefore, stop all work and ventilate to disperse refrigerant vapors from the work area before using any open flames.

HFC-23 is not flammable in air at temperatures up to 100 deg. C (212 deg. F) at atmospheric pressure. However, mixtures of HFC-23 with high concentrations of air at elevated pressure and/or temperature can become combustible in the presence of an ignition source. HFC-23 can also become combustible in an oxygen enriched environment (oxygen concentrations greater than that in air). Whether a mixture containing HFC-23 and air, or HFC-23 in an oxygen enriched atmosphere become combustible depends on the inter-relationship of 1) the temperature, 2) the pressure, and 3) the proportion of oxygen in the mixture. In general, HFC-23 should not be allowed to exist with air above atmospheric pressure or at high temperatures; or in an oxygen enriched environment. For example, HFC-23 should NOT be mixed with air under pressure for leak testing or other purposes.

Extinguishing Media

As appropriate for combustibles in area.

Fire Fighting Instructions

Use water spray or fog to cool containers. Self-contained breathing apparatus (SCBA) is required if cylinders rupture or release under fire conditions. Water runoff should be contained and neutralized prior to release.

ACCIDENTAL RELEASE MEASURES

Safeguards (Personnel)

NOTE: Review FIRE FIGHTING MEASURES and HANDLING (PERSONNEL) sections before proceeding with clean-up. Use appropriate PERSONAL PROTECTIVE EQUIPMENT during clean-up.

Accidental Release Measures

Material evaporates at atmospheric pressure (vaporizes). Ventilate area, especially low places where heavy vapors might collect. Remove open flames. Wear self-contained breathing apparatus (SCBA) for large spills or when a release occurs.

DuPont Fire Emergency Exposure Limits (FEEL) are established to facilitate the safe release of a fire extinguishant into spaces normally occupied by people to extinguish a fire or prevent an explosion and specify airborne concentrations of brief durations which should not result in permanent adverse health effects or interfere with escape. For more information on the applicability of FEEL's, contact DuPont. The DuPont Fire Emergency Exposure Limit (FEEL) for this material is 20% v/v for up to 15 minutes with a 1 minute not-to-exceed ceiling of 23% v/v.

HANDLING AND STORAGE

Handling (Personnel)

Avoid breathing high concentrations of vapor. Avoid contact of liquid with eyes and prolonged skin exposure. Use with sufficient ventilation to keep employee exposure below recommended limits.

Storage

Valve protection caps and valve outlet threaded plugs must remain in place unless container is secured with valve outlet piped to use point. Do NOT drag, slide or roll cylinders. Use a suitable hand truck for cylinder movement. Never attempt to lift cylinder by its cap. Use a pressure reducing regulator when connecting cylinder to lower pressure piping or systems. Do NOT heat cylinder. Use a check valve or trap in the discharge line to prevent hazardous back flow into the cylinder.

Cylinders should be stored upright and firmly secured to prevent falling or being knocked over. Separate full containers from empty containers. Storage area temperatures should not exceed 125 deg F (52 deg C) and should be free of combustible materials. Avoid area where salt or other corrosive materials are present. Avoid excessive inventory

(HANDLING AND STORAGE - Continued)

and storage time. Use a first-in first-out system. Keep accurate inventory records.

EXPOSURE CONTROLS/PERSONAL PROTECTION

Engineering Controls

Normal ventilation for routine manufacturing procedures is generally adequate. Local exhaust should be used when large amounts are released. Mechanical ventilation should be used in low or enclosed places.

Personal Protective Equipment

Impervious gloves should be used when handling liquid. Chemical splash goggles should be worn when handling liquid. Under normal manufacturing conditions, no respiratory protection is required when using this product. Self-contained breathing apparatus (SCBA) is required if a large spill or release occurs.

Exposure Guidelines

Exposure Limits

"FREON" 23
PEL (OSHA) : None Established
TLV (ACGIH) : None Established
AEL * (DuPont) : 1000 ppm, 8 & 12 Hr. TWA

* AEL is DuPont's Acceptable Exposure Limit. Where governmentally imposed occupational exposure limits which are lower than the AEL are in effect, such limits shall take precedence.

PHYSICAL AND CHEMICAL PROPERTIES

Physical Data

Boiling Point : -82.1 C (-115.8 F)
Vapor Pressure : 686 psig at 25 deg C (77 deg F)
Vapor Density : 2.4 (Air = 1)
% Volatiles : 100 WT%
Solubility in Water : 0.1 WT% @ 25 C (77 F)
Odor : Slight ethereal
Form : Compressed gas or liquefied gas
Color : Clear, colorless
Density : 1.44 g/cc at -82 deg C (-115.7 deg F)

STABILITY AND REACTIVITY

Chemical Stability

Material is stable. However, avoid open flames and high temperatures.

Incompatibility with Other Materials

Incompatible with alkali or alkaline earth metals - powdered Al, Zn, Be, etc.

Decomposition

Decomposition products are hazardous. This material can be decomposed by high temperatures (open flames, glowing metal surfaces, etc.) forming HF, COF₂, or CO. These materials are toxic and irritating. Contact should be avoided.

Polymerization

Polymerization will not occur.

TOXICOLOGICAL INFORMATION

Animal Data

Inhalation 4-hour LC50: >663,000 ppm in rats

HFC-23 is untested for skin and eye irritancy, and for animal sensitization.

Effects from single high inhalation exposure to HFC-23 include anaesthetic effects, and nonspecific effects such as weight loss were observed at concentrations >22%. No cardiac sensitization was observed in dogs after breathing 800,000 ppm for periods of 5-10 minutes following epinephrine challenge. In another test, dogs exposed to up to 30% or up to 50% (with additional oxygen), had no positive responses. No cardiac sensitization occurred in baboons exposed by inhalation to 10%, 30%, 50%, or 70% HFC-23 before or after an epinephrine challenge; there was a dose-related decrease in heart rates and differences in respiratory rates during exposure.

No animal tests are available to define the carcinogenic hazards of HFC-23. The maternal and developmental NOAEL was 50,000 ppm. HFC-23 is not considered a unique developmental hazard to the conceptus. There were no developmental or reproductive effects.

Tests have shown that HFC-23 does not produce genetic damage in bacterial or mammalian cell cultures. It has not produced genetic damage in tests on animals.

DISPOSAL CONSIDERATIONS

Waste Disposal

Reclaim by distillation or remove to permitted waste facility. Dispose of in accordance with all Federal, State, and local regulations.

TRANSPORTATION INFORMATION

Shipping Information

DOT/IMO/IATA
Proper Shipping Name : Trifluoromethane
Hazard Class : 2.2
UN No. : 1984
DOT/IMO Label : Nonflammable Gas

Shipping Containers

Cylinders
Ton Tanks
Tank Trucks

REGULATORY INFORMATION

U.S. Federal Regulations

TSCA Inventory Status : Reported/Included.

TITLE III HAZARD CLASSIFICATIONS SECTIONS 311, 312

Acute : Yes
Chronic : No
Fire : No
Reactivity : No
Pressure : Yes

HAZARDOUS CHEMICAL LISTS

SARA Extremely
Hazardous Substance - No
CERCLA Hazardous Substance - No
SARA Toxic Chemical - No

OTHER INFORMATION

NFPA, NPCA-HMIS

NPCA-HMIS Rating
Health : 1
Flammability : 0
Reactivity : 1

Personal Protection rating to be supplied by user depending on use conditions.

The data in this Material Safety Data Sheet relates only to the specific material designated herein and does not relate to use in combination with any other material or in any process.

Responsibility for MSDS : MSDS Coordinator
> : DuPont Fluoroproducts
Address : Wilmington, DE 19898
Telephone : (800) 441-7515

Indicates updated section.

This information is based upon technical information believed to be reliable. It is subject to revision as additional knowledge and experience is gained.

End of MSDS

SAFETY DATA SHEET

ISCEON 89

Page: 1 / 8

Date: 01/08/2003

Version: 3.03 UK

Cancels and replaces version: 2.00 UK

1 Product and company identification.

PRODUCT NAME : ISCEON 89
Use : Refrigerant.
SUPPLIER : Manufacturer :
Name : Rhodia Organique Fine Limited.
Address : PO Box 46 - St Andrews Road - Avonmouth - BRISTOL - BS11 9YF - England
Telephone number : (44) 0117 948 4242
Telefax number : (44) 0117 948 4249.
EMERGENCY TELEPHONE NUMBER : **00 44 117 938 1289 (UK: 0117 938 1289)**

2 Composition / information on ingredients

>> PREPARATION

Chemical nature : Predominantly hydrofluoroalkane mixture.

3 Hazards identification

MOST IMPORTANT HAZARDS

Adverse human health effects

: Contains a liquefied gas. Contact of liquid may cause frostbite and injury to the cornea.

Main symptoms

: May have a narcotic effect at high concentrations.

Physical and chemical hazards

- Fire or explosion

: Heating will cause a rise in pressure with a risk of bursting. On combustion, toxic gases are released.

Classification/Specific hazards

: According to EC criteria, this product is not classified as a "hazardous preparation".

SAFETY DATA SHEET

ISCEON 89

Page: 2/8

Date: 01/08/2003

Version: 3.03 UK

Cancels and replaces version: 2.00 UK

4 First-aid measures

- Inhalation : Move the affected person away from the contaminated area and into the fresh air.
Make the affected person rest.
If breathing stops, give artificial respiration.
Call a doctor immediately.
- Skin contact : Contact of liquid with the skin:
Rinse immediately with plenty of warm water.
Immediately remove contaminated clothing or footwear.
If it sticks, do not pull it off.
Cover the affected area with a sterile dressing.
Transfer to hospital immediately.
- Eye contact : Contact of liquid with the eyes:
Rinse with water whilst keeping the eyes wide open.
Consult an eye specialist immediately.
- Ingestion : Not specifically applicable (gas).
- Notes to the physician : Avoid administering adrenaline or any other similar products.

5 Fire - fighting measures

- Extinguishing media
- Suitable : All extinguishing agents can be used.
 - Not suitable : None. If there is a fire close by, use suitable extinguishing agents.
- Specific hazards : Pressurized container. On heating there is a risk of bursting due to internal pressure build-up.
NOT flammable. However, it may present a risk in the event of a fire.
Toxic vapours (halogen compounds) are released.
Vapour / air mixture may be flammable under specific conditions.
- Specific fire fighting methods : Stay upwind.
Evacuate the personnel away from the fumes.
Cool down the containers/equipment exposed to heat with a water spray.
- Protection of fire-fighters : Self-contained breathing apparatus.

SAFETY DATA SHEET

ISCEON 89

Page: 3/8

Date: 01/08/2003

Version: 3.03 UK

Cancels and replaces version: 2.00 UK

6 Accidental release measures

Personal precautions

- : Avoid contact with skin and eyes.
Do not breathe gas.
NO naked flames.
Do NOT smoke.
For further information refer to section 8 "Exposure-controls/personal protection".
Heavy vapours. Shut off low-level openings in the vicinity (ventilation shafts, drains...).
- Prevent the product from entering cellars, basements or pits.
Stop the leak.
Ventilate spillage area.
Ventilate basements.

Environmental precautions

- : Prevent the product from spreading into the environment.
Contain the spilled material by bunding.

Methods for cleaning up

- Recovery : Recover as much of the product as possible.
 - Cleaning/Decontamination : Allow residual product to evaporate.
 - Disposal : For disposal of contaminated materials refer to section 13: "Disposal considerations".
-

7 Handling and storage

HANDLING

Technical measures

- : Ventilation.
Use in a closed system.

Measures

- : Avoid contact with hot surfaces.
Avoid high temperatures.
Smoking is forbidden.

STORAGE

Technical measures

- : Storage facilities should be:
equipped with ventilation at low level.
Take all necessary precautions to avoid the accidental release of the product outside, due to the rupture of containers or transfer systems.

Storage conditions

SAFETY DATA SHEET

ISCEON 89

Page: 4/8

Date: 01/08/2003

Version: 3.03 UK

Cancel and replaces version: 2.00 UK

- Recommended	:	Keep: <ul style="list-style-type: none">- the container tightly closed and dry.- in a cool, well-ventilated area.- at temperatures not exceeding 45°C.- away from any source of heat.- away from any source of ignition.
Incompatible products	:	Refer to the detailed list of incompatible materials (section 10 "Stability/Reactivity").
Packaging	:	- Steel cylinders.
Packaging materials	:	
- Recommended	:	Steel.
- Not suitable	:	Magnesium and its alloys. Zinc and its alloys. Aluminium alloys containing more than 2% magnesium.

8 Exposure controls / personal protection

Engineering measures	:	Ensure good ventilation of the work station.
Control parameters	:	
Occupational exposure limits	:	
- Limits (UK)	:	No specific limits.
Personal protective equipment	:	
- Respiratory protection	:	In the event of insufficient ventilation: Self-contained breathing apparatus.
- Hand protection	:	Handling refrigerated product: Protective gloves insulated against the cold.
- Eye protection	:	Handling refrigerated product: Goggles.
- Skin and body protection	:	Handling refrigerated product: Impermeable clothing.
Hygiene measures	:	Do NOT drink, eat or smoke in the workplace.

9 Physical and chemical properties

APPEARANCE

- Physical state	:	Compressed liquefied gas.
- Colour	:	colourless.
Odour	:	slightly ethereal.
pH	:	Not applicable
Specific temperatures	:	

SAFETY DATA SHEET

ISCEON 89

Page: 5/8

Date: 01/08/2003

Version: 3.03 UK

Cancels and replaces version: 2.00 UK

- Boiling	:	-54°C.
Flammability characteristics		
- Flash point	:	Not applicable.
Oxidizing properties	:	Non oxidizing material according to EC criteria.
Vapour pressure	:	1555 kPa, at 25°C.
Specific gravity	:	1180 kg/m ³ at 25°C.
Solubility		
- in water	:	Slightly soluble.
- in organic solvents	:	Soluble in: - common solvents.

10 Stability and reactivity.

Stability		Stable at ambient temperature and under normal conditions of use.
Hazardous reactions		
- Conditions to avoid		May decompose: - on contact with hot surfaces and flames.
- Materials to avoid	:	Reacts violently with: - alkali metals. - alkaline earth metals. - magnesium. - powdered metals.
- Hazardous decomposition products	:	On combustion or on thermal decomposition (pyrolysis) releases: toxic gases. (Halogenated compounds) (Hydrofluoric acid).

11 Toxicological information

Acute toxicity		
Acute symptoms		Effects following high level exposure: Headaches. Dizziness. Loss of consciousness. Possible effects, following high level exposure: Cardiac disorders. Possibility of cardiac arrest.
Local effects		Contact with liquefied gas causes frostbite. Contact with liquefied gas causes injury to the cornea.
Further information	:	Not classified as hazardous according to EEC criteria.

SAFETY DATA SHEET

ISCEON 89

Page: 6/8

Date: 01/08/2003

Version: 3.03 UK

Cancels and replaces version: 2.00 UK

12 Ecological information

Behaviour in the environment

- Mobility : Product is volatile when in aqueous solution.
Persistence/Degradability : No information available.
Bioaccumulation : No information available.
Destination of the product : Ultimate destination of the product : AIR.
Ecotoxicity
- Effects on the aquatic environment : No information available.

13 Disposal considerations

WASTE FROM RESIDUES

- Prohibition : Do not allow the product to be released into the environment.
Destruction/Disposal : Consult the manufacturer or supplier for information regarding recovery and recycling of the product.
If recovery is not possible:
Incinerate at a licensed installation.

CONTAMINATED PACKAGING

- Decontamination/cleaning : De-gas.
Destruction/Disposal : Re-usable containers:
Return to the supplier.
Disposable containers:
Dispose of at an authorised land-fill site.

- NOTE : The user's attention is drawn to the possible existence of local regulations regarding disposal.

14 Transport information

INTERNATIONAL REGULATIONS

Land

- Rail/road (RID/ADR) : UN number: 3163.
Class:2.2.
Hazard identification number: 20.
Labelling: 2.2.

SAFETY DATA SHEET

ISCEON 89

Page: 7/8

Date: 01/08/2003

Version: 3.03 UK

Cancel and replaces version: 2.00 UK

Sea (IMO/IMDG)

: Class: 2.2.
UN Number: 3163.
Labelling: 2 NON-FLAMMABLE GAS.
Marine pollutant: NO.

Air (ICAO-IATA)

Class: 2.2.
UN number: 3163.
Labelling: 2 NON-FLAMMABLE GAS.
Cargo aircraft : Packing instruction: 200 Quantity : 150 kg.
Passenger aircraft: Packing instruction: 200 Quantity : 75 kg.

OTHER REGULATIONS

- United Kingdom: Rail/road

Substance identification number: 3163.
Classification for conveyance: 2.2.
Emergency action code: 2RE.

NOTE

The above regulatory prescriptions are those valid on the date of publication of this sheet.
Given the possible evolution of transport regulations for hazardous materials, it would be advisable to check their validity with your sales office.

15 Regulatory information

LABELLING

EC regulations

: Mandatory labelling (self-classification) of hazardous preparations:
Not applicable.

- R phrases

: No R phrases.

- S phrases

: S 24/25: Avoid contact with skin and eyes.
S 41: In case of fire and/or explosion do not breathe fumes.

>>Further regulations

United Kingdom

: Handle in accordance with relevant British legislation:
Environmental Protection Act
Carriage of Dangerous Goods by Road Regulations
Carriage of Dangerous Goods by Rail Regulations
Carriage of Dangerous Goods by Road and Rail (Classification, Packaging and Labelling) and use of Transport Pressure Receptacles Regulations

NOTE

: The regulatory information given above only indicates the principal regulations specifically applicable to the product described in the Safety Data Sheet. The user's attention is drawn to the possible existence of additional provisions which complete these regulations. Refer to all applicable national, international and local regulations or provisions.

SAFETY DATA SHEET

ISCEON 89

Page: 8/8

Date: 01/08/2003

Version: 3.03 UK

Cancels and replaces version: 2.00 UK

16 Other information

* Update

- European inventory (EINECS, ELINCS)

- American inventory (TSCA)

- : This sheet was updated (refer to the date at the top of this page). Subheadings and text which have been modified since the previous version are indicated with an asterisk (*).
- : All the constituents of this preparation are registered in the EINECS inventory.
- : All the components of this preparation are registered in the TSCA inventory.

This safety data sheet should be used in conjunction with technical sheets. It does not replace them. The information given is based on our knowledge of this product, at the time of publication. It is given in good faith. The attention of the user is drawn to the possible risks incurred by using the product for any other purpose other than that for which it was intended. This does not in any way excuse the user from knowing and applying all the regulations governing his activity. It is the sole responsibility of the user to take all precautions required in handling the product. The aim of the mandatory regulations mentioned is to help the user to fulfil his obligations regarding the use of hazardous products. This information is not exhaustive. This does not exonerate the user from ensuring that legal obligations, other than those mentioned, relating to the use and storage of the product, do not exist. This is solely his responsibility.

Material Safety Data Sheet

Genetron[®] 22

1. CHEMICAL PRODUCT AND COMPANY IDENTIFICATION

PRODUCT NAME: Genetron[®] 22
OTHER/GENERIC NAMES: R-22, HCFC-22
PRODUCT USE: Refrigerant
MANUFACTURER: Honeywell
101 Columbia Road
Box 1053
Morristown, New Jersey 07962-1053

FOR MORE INFORMATION CALL:
(Monday-Friday, 9:00am-5:00pm)
1-800-522-8001

IN CASE OF EMERGENCY CALL:
(24 Hours/Day, 7 Days/Week)
CHEMTREC 1-800-424-9300 or 703-527-3887

2. COMPOSITION/INFORMATION ON INGREDIENTS

<u>INGREDIENT NAME</u>	<u>CAS NUMBER</u>	<u>WEIGHT %</u>
Chlorodifluoromethane	75-45-6	100

Trace impurities and additional material names not listed above may also appear in Section 15 toward the end of the MSDS. These materials may be listed for local "Right-To-Know" compliance and for other reasons.

3. HAZARDS IDENTIFICATION

EMERGENCY OVERVIEW: Colorless, volatile liquid with ethereal and faint sweetish odor. Non-flammable material. Overexposure may cause dizziness and loss of concentration. At higher levels, CNS depression and cardiac arrhythmia may result from exposure. Vapors displace air and can cause asphyxiation in confined spaces. At higher temperatures, (>250°C), decomposition products may include Hydrochloric Acid (HCl), Hydrofluoric Acid (HF) and carbonyl halides.

POTENTIAL HEALTH HAZARDS

SKIN: Irritation would result from a defatting action on tissue. Liquid contact could cause frostbite.

EYES: Liquid contact can cause severe irritation and frostbite. Mist may irritate.

INHALATION: Genetron 22 is low in acute toxicity in animals. When oxygen levels in air are reduced to 12–14% by displacement, symptoms of asphyxiation, loss of coordination, increased pulse rate and deeper respiration will occur. At high levels, cardiac arrhythmia may occur.

MATERIAL SAFETY DATA SHEET

Genetron[®] 22

INGESTION: Ingestion is unlikely because of the low boiling point of the material. Should it occur, discomfort in the gastrointestinal tract from rapid evaporation of the material and consequent evolution of gas would result. Some effects of inhalation and skin exposure would be expected.

DELAYED EFFECTS: None known

Ingredients found on one of the OSHA designated carcinogen lists are listed below.

<u>INGREDIENT NAME</u>	<u>NTP STATUS</u>	<u>IARC STATUS</u>	<u>OSHA LIST</u>
No ingredients listed in this section			

4. FIRST AID MEASURES

SKIN: Promptly flush skin with water until all chemical is removed. If there is evidence of frostbite, bathe (do not rub) with lukewarm (not hot) water. If water is not available, cover with a clean, soft cloth or similar covering. Get medical attention if symptoms persist.

EYES: Immediately flush eyes with large amounts of water for at least 15 minutes (in case of frostbite water should be lukewarm, not hot) lifting eyelids occasionally to facilitate irrigation. Get medical attention if symptoms persist.

INHALATION: Immediately remove to fresh air. If breathing has stopped, give artificial respiration. Use oxygen as required, provided a qualified operator is available. Get medical attention. Do not give epinephrine (adrenaline).

INGESTION: Ingestion is unlikely because of the physical properties and is not expected to be hazardous. Do not induce vomiting unless instructed to do so by a physician.

ADVICE TO PHYSICIAN: Because of the possible disturbances of cardiac rhythm, catecholamine drugs, such as epinephrine, should be used with special caution and only in situations of emergency life support. Treatment of overexposure should be directed at the control of symptoms and the clinical conditions.

5. FIRE FIGHTING MEASURES

FLAMMABLE PROPERTIES

FLASH POINT: Gas, not applicable per DOT regulations

FLASH POINT METHOD: Not applicable

AUTOIGNITION TEMPERATURE: Unknown

UPPER FLAME LIMIT (volume % in air): None*

LOWER FLAME LIMIT (volume % in air): None*

*Based on ASHRAE Standard 34 with match ignition

FLAME PROPAGATION RATE (solids): Not applicable

OSHA FLAMMABILITY CLASS: Not applicable

EXTINGUISHING MEDIA:

Use any standard agent – choose the one most appropriate for type of surrounding fire (material itself is not flammable)

MATERIAL SAFETY DATA SHEET

Genetron[®] 22

UNUSUAL FIRE AND EXPLOSION HAZARDS:

Genetron 22 is not flammable at ambient temperatures and atmospheric pressure. However, this material will become combustible when mixed with air under pressure and exposed to strong ignition sources.

Contact with certain reactive metals may result in formation of explosive or exothermic reactions under specific conditions (e.g. very high temperatures and/or appropriate pressures).

SPECIAL FIRE FIGHTING PRECAUTIONS/INSTRUCTIONS:

Firefighters should wear self-contained, NIOSH-approved breathing apparatus for protection against possible toxic decomposition products. Proper eye and skin protection should be provided. Use water spray to keep fire-exposed containers cool.

6. ACCIDENTAL RELEASE MEASURES

IN CASE OF SPILL OR OTHER RELEASE:

(Always wear recommended personal protective equipment.)

Evacuate unprotected personnel. Protected personnel should remove ignition sources and shut off leak, if without risk, and provide ventilation. Unprotected personnel should not return until air has been tested and determined safe, including low-lying areas.

Spills and releases may have to be reported to Federal and/or local authorities. See Section 15 regarding reporting requirements.

7. HANDLING AND STORAGE

NORMAL HANDLING:

(Always wear recommended personal protective equipment.)

Avoid breathing vapors and liquid contact with eyes, skin or clothing. Do not puncture or drop cylinders, expose them to open flame or excessive heat. Use authorized cylinders only. Follow standard safety precautions for handling and use of compressed gas cylinders.

Genetron 22 should not be mixed with air above atmospheric pressure for leak testing or any other purpose. See Section 5: Unusual Fire and Explosion Hazards

STORAGE RECOMMENDATIONS:

Store in a cool, well-ventilated area of low fire risk and out of direct sunlight. Protect cylinder and its fittings from physical damage. Storage in subsurface locations should be avoided. Close valve tightly after use and when empty.

8. EXPOSURE CONTROLS/PERSONAL PROTECTION

ENGINEERING CONTROLS:

Provide local ventilation at filling zones and areas where leakage is probable. Mechanical (general) ventilation may be adequate for other operating and storage areas.

PERSONAL PROTECTIVE EQUIPMENT

SKIN PROTECTION:

Skin contact with refrigerant may cause frostbite. General work clothing and gloves (leather) should provide adequate protection. If prolonged contact with the liquid or gas is anticipated, insulated gloves constructed of PVA, neoprene or butyl rubber should be used. Any contaminated clothing should be promptly removed and washed before reuse.

MATERIAL SAFETY DATA SHEET Genetron[®] 22

EYE PROTECTION:

For normal conditions, wear safety glasses. Where there is reasonable probability of liquid contact, wear chemical safety goggles.

RESPIRATORY PROTECTION:

None generally required for adequately ventilated work situations. For accidental release or non-ventilated situations, or release into confined space, where the concentration may be above the PEL of 1,000 ppm, use a self-contained, NIOSH - approved breathing apparatus or supplied air respirator. For escape: use the former or a NIOSH-approved gas mask with organic vapor canister.

ADDITIONAL RECOMMENDATIONS:

Where contact with liquid is likely, such as in a spill or leak, impervious boots and clothing should be worn. High dose-level warning signs are recommended for areas of principle exposure. Provide eyewash stations and quick-drench shower facilities at convenient locations. For tank cleaning operations, see OSHA regulations, 29 CFR 1910.132 and 29 CFR 1910.133.

EXPOSURE GUIDELINES

<u>INGREDIENT NAME</u>	<u>ACGIH TLV</u>	<u>OSHA PEL</u>	<u>OTHER LIMIT</u>
Chlorodifluoromethane	1000 ppm TWA (8hr)	1000 ppm TWA (8hr)	None

- * = Limit established by Honeywell.
- ** = Workplace Environmental Exposure Level (AIHA).
- *** = Biological Exposure Index (ACGIH).

OTHER EXPOSURE LIMITS FOR POTENTIAL DECOMPOSITION PRODUCTS:

Hydrogen Fluoride: ACGIH TLV = 3 ppm ceiling

9. PHYSICAL AND CHEMICAL PROPERTIES

APPEARANCE: Clear, colorless liquid and vapor

PHYSICAL STATE: Gas at ambient temperatures

MOLECULAR WEIGHT: 86.45

CHEMICAL FORMULA: CHClF₂

ODOR: Faint ethereal odor

SPECIFIC GRAVITY (water = 1.0): 1.21 @ 21.1°C (70°F)

SOLUBILITY IN WATER (weight %): 0.3 wt% @ 25°C and 1 atmosphere

pH: Neutral

BOILING POINT: -40.8°C (-41.40°F)

FREEZING POINT: -160°C (-256°F)

VAPOR PRESSURE: 136.1 psia @ 70°F

311.4 psia @ 130°F

VAPOR DENSITY (air = 1.0): 3.0

EVAPORATION RATE: >1

COMPARED TO: CCl₄ = 1

% VOLATILES: 100

FLASH POINT: Not applicable

MATERIAL SAFETY DATA SHEET

Genetron[®] 22

(Flash point method and additional flammability data are found in Section 5.)

10. STABILITY AND REACTIVITY

NORMALLY STABLE? (CONDITIONS TO AVOID):

The product is stable.

Do not mix with oxygen or air above atmospheric pressure. Any source of high temperature, such as lighted cigarettes, flames, hot spots or welding may yield toxic and/or corrosive decomposition products.

INCOMPATIBILITIES:

(Under specific conditions: e.g. very high temperatures and/or appropriate pressures) – Freshly abraded aluminum surfaces (may cause strong exothermic reaction). Chemically active metals: potassium, calcium, powdered aluminum, magnesium and zinc.

HAZARDOUS DECOMPOSITION PRODUCTS:

Halogens, halogen acids and possibly carbonyl halides.

HAZARDOUS POLYMERIZATION:

Will not occur.

11. TOXICOLOGICAL INFORMATION

IMMEDIATE (ACUTE) EFFECTS:

LC₅₀ : 4 hr. (rat) - ≥300,000 ppm
Cardiac Sensitization threshold (dog) – 50,000 ppm

DELAYED (SUBCHRONIC AND CHRONIC) EFFECTS:

Subchronic inhalation (rat) NOEL - 10,000 ppm
Not teratogenic
Not mutagenic in *in-vitro* or *in-vivo* tests

OTHER DATA:

Lifetime exposure of male rats was associated with a small increase in salivary gland fibrosarcomas.

12. ECOLOGICAL INFORMATION

Degradability (BOD): Genetron 22 is a gas at room temperature; therefore, it is unlikely to remain in water.

Octanol Water Partition Coefficient: Unknown

13. DISPOSAL CONSIDERATIONS

RCRA

Is the unused product a RCRA hazardous waste if discarded? Not a hazardous waste

If yes, the RCRA ID number is: Not applicable

MATERIAL SAFETY DATA SHEET

Genetron[®] 22

OTHER DISPOSAL CONSIDERATIONS:

Disposal must comply with federal, state, and local disposal or discharge laws. Genetron 22 is subject to U.S. Environmental Protection Agency Clean Air Act Regulations Section 608 in 40 CFR Part 82 regarding refrigerant recycling.

The information offered here is for the product as shipped. Use and/or alterations to the product such as mixing with other materials may significantly change the characteristics of the material and alter the RCRA classification and the proper disposal method.

14. TRANSPORT INFORMATION

US DOT HAZARD CLASS: US DOT PROPER SHIPPING NAME: Chlorodifluoromethane
US DOT HAZARD CLASS: 2.2
US DOT PACKING GROUP: Not applicable

US DOT ID NUMBER: UN1018

For additional information on shipping regulations affecting this material, contact the information number found in Section 1.

15. REGULATORY INFORMATION

TOXIC SUBSTANCES CONTROL ACT (TSCA)

TSCA INVENTORY STATUS: Listed on the TSCA inventory

OTHER TSCA ISSUES: None

SARA TITLE III/CERCLA

"Reportable Quantities" (RQs) and/or "Threshold Planning Quantities" (TPQs) exist for the following ingredients.

<u>INGREDIENT NAME</u>	<u>SARA/CERCLA RQ (lb.)</u>	<u>SARA EHS TPO (lb.)</u>
No ingredients listed in this section		

Spills or releases resulting in the loss of any ingredient at or above its RQ requires immediate notification to the National Response Center [(800) 424-8802] and to your Local Emergency Planning Committee.

SECTION 311 HAZARD CLASS: IMMEDIATE
PRESSURE

SARA 313 TOXIC CHEMICALS:

The following ingredients are SARA 313 "Toxic Chemicals". CAS numbers and weight percents are found in Section 2.

<u>INGREDIENT NAME</u>	<u>COMMENT</u>
Chlorodifluoromethane (HCFC-22)	None

MATERIAL SAFETY DATA SHEET Genetron[®] 22

STATE RIGHT-TO-KNOW

In addition to the ingredients found in Section 2, the following are listed for state right-to-know purposes.

<u>INGREDIENT NAME</u>	<u>WEIGHT %</u>	<u>COMMENT</u>
No ingredients listed in this section		

ADDITIONAL REGULATORY INFORMATION:

Genetron 22 is subject to U.S. Environmental Protection Agency Clean Air Act Regulations at 40 CFR Part 82.

WARNING:

Do Not vent to the atmosphere. To comply with provisions of the U.S. Clean Air Act, any residual must be recovered. **Contains Chlorodifluoromethane**, an HCFC substance which harms public health and the environment by destroying ozone in the upper atmosphere. Destruction of the ozone layer can lead to increased ultraviolet radiation which, with excess exposure to sunlight, can lead to an increase in skin cancer and eye cataracts.

WHMIS CLASSIFICATION (CANADA):

This product has been evaluated in accordance with the hazard criteria of the CPR and the MSDS contains all the information required by the CPR.

FOREIGN INVENTORY STATUS:

Canada – Listed on DSL
EU – EINECS # 2008719

16. OTHER INFORMATION

CURRENT ISSUE DATE: January, 2004

PREVIOUS ISSUE DATE: February, 2003

CHANGES TO MSDS FROM PREVIOUS ISSUE DATE ARE DUE TO THE FOLLOWING:

Section 3: Revised decomposition products

OTHER INFORMATION: HMIS Classification: Health – 1, Flammability – 1, Reactivity – 0
NFPA Classification: Health – 2, Flammability – 1, Reactivity – 0
ANSI/ASHRAE 34 Safety Group – A1
UL Classified

Regulatory Standards:

1. OSHA regulations for compressed gases: 29 CFR 1910.101
2. DOT classification per 49 CFR 172.101
3. Clean Air Act Class II Substance



The MSDS format adheres to the standards and regulatory requirements of the United States and may not meet regulatory requirements in other countries.

DuPont
Material Safety Data Sheet

Page 1

6002FR "SUVA" 404A
Revised 29-AUG-2001

CHEMICAL PRODUCT/COMPANY IDENTIFICATION

Material Identification

"SUVA" is a registered trademark of DuPont.

Corporate MSDS Number : DU005612

Tradenames and Synonyms

HP62
404A

Company Identification

MANUFACTURER/DISTRIBUTOR

DuPont Fluoroproducts
1007 Market Street
Wilmington, DE 19898

PHONE NUMBERS

Product Information : 1-800-441-7515 (outside the U.S.
302-774-1000)
Transport Emergency : CHEMTREC 1-800-424-9300(outside U.S.
703-527-3887)
Medical Emergency : 1-800-441-3637 (outside the U.S.
302-774-1000)

COMPOSITION/INFORMATION ON INGREDIENTS

Components

Material	CAS Number	%
PENTAFLUOROETHANE (HFC-125)	354-33-6	44
ETHANE, 1,1,1-TRIFLUORO- (HFC-143a)	420-46-2	52
	811-97-2	
ETHANE, 1,1,1,2-TETRAFLUORO- (HFC-134a)		4

HAZARDS IDENTIFICATION

Potential Health Effects

Inhalation of high concentrations of vapor is harmful and may cause heart irregularities, unconsciousness, or death. Intentional misuse or deliberate inhalation may cause death without warning. Vapor reduces oxygen available for breathing and is heavier than air. Liquid contact can cause frostbite.

(HAZARDS IDENTIFICATION - Continued)

HUMAN HEALTH EFFECTS:

Overexposure to the vapors by inhalation may include temporary nervous system depression with anesthetic effects such as dizziness, headache, confusion, incoordination, and loss of consciousness. Higher exposures to the vapors may cause temporary alteration of the heart's electrical activity with irregular pulse, palpitations, or inadequate circulation; or fatality from gross overexposure. Contact with the liquid may cause frostbite.

Individuals with preexisting diseases of the central nervous or cardiovascular system may have increased susceptibility to the toxicity of increased exposures.

Carcinogenicity Information

None of the components present in this material at concentrations equal to or greater than 0.1% are listed by IARC, NTP, OSHA or ACGIH as a carcinogen.

FIRST AID MEASURES

First Aid

INHALATION

If inhaled, immediately remove to fresh air. Keep person calm. If not breathing, give artificial respiration. If breathing is difficult, give oxygen. Call a physician.

SKIN CONTACT

Flush area with lukewarm water. Do not use hot water. If frostbite has occurred, call a physician.

EYE CONTACT

In case of contact, immediately flush eyes with plenty of water for at least 15 minutes. Call a physician.

INGESTION

Not a probable route. However, in case of accidental ingestion, call a physician.

Notes to Physicians

THIS MATERIAL MAY MAKE THE HEART MORE SUSCEPTIBLE TO ARRHYTHMIAS. Catecholamines such as adrenaline, and other compounds having similar effects, should be reserved for emergencies and then used only with special caution.

FIRE FIGHTING MEASURES

Flammable Properties

Flash Point : No flash point

Flammable Limits in Air, % by Volume:

LEL : None per ASTM E681

UEL : None per ASTM E681

Autoignition: Not determined

Fire and Explosion Hazards:

Cylinders may rupture under fire conditions. Decomposition may occur.

Contact of welding or soldering torch flame with high concentrations of refrigerant can result in visible changes in the size and color of torch flames. This flame effect will only occur in concentrations of product well above the recommended exposure limit, therefore stop all work and ventilate to disperse refrigerant vapors from the work area before using any open flames.

R-404A is not flammable in air at temperatures up to 100 deg C (212 deg F) at atmospheric pressure. However, mixtures of R-404A with high concentrations of air at elevated pressure and/or temperature can become combustible in the presence of an ignition source. R-404A can also become combustible in an oxygen enriched environment (oxygen concentrations greater than that in air). Whether a mixture containing R-404A and air, or R-404A in an oxygen enriched atmosphere becomes combustible depends on the inter-relationship of 1) the temperature 2) the pressure, and 3) the proportion of oxygen in the mixture. In general, R-404A should not be allowed to exist with air above atmospheric pressure or at high temperatures; or in an oxygen enriched environment. For example: R-404A should NOT be mixed with air under pressure for leak testing or other purposes.

Experimental data have also been reported which indicate combustibility of HFC-134a, a component in this blend, in the presence of chlorine.

Extinguishing Media

As appropriate for combustibles in area.

Fire Fighting Instructions

Cool cylinder with water spray or fog. Self-contained breathing apparatus (SCBA) is required if cylinders rupture and contents are released under fire conditions. Water runoff should be contained and neutralized prior to release.

ACCIDENTAL RELEASE MEASURES

Safeguards (Personnel)

NOTE: Review FIRE FIGHTING MEASURES and HANDLING (PERSONNEL) sections before proceeding with clean-up. Use appropriate PERSONAL PROTECTIVE EQUIPMENT during clean-up.

Accidental Release Measures

Ventilate area using forced ventilation, especially in low or enclosed places where heavy vapors might collect. Remove open flames. Use self-contained breathing apparatus (SCBA) for large spills or releases.

HANDLING AND STORAGE

Handling (Personnel)

Avoid breathing vapor. Avoid liquid contact with eyes and skin. Use with sufficient ventilation to keep employee exposure below recommended limits. Contact with chlorine or other strong oxidizing agents should also be avoided. See Fire and Explosion Data section.

Storage

Clean, dry area. Do not heat above 52 deg C (125 deg F).

EXPOSURE CONTROLS/PERSONAL PROTECTION

Engineering Controls

Avoid breathing vapors. Avoid contact with skin or eyes. Use with sufficient ventilation to keep employee exposure below the recommended exposure limit. Local exhaust should be used if large amounts are released. Mechanical ventilation should be used in low or enclosed places.

Refrigerant concentration monitors may be necessary to determine vapor concentrations in work areas prior to use of torches or other open flames, or if employees are entering enclosed areas.

Personal Protective Equipment

Impervious gloves should be used to avoid prolonged or repeated exposure. Chemical splash goggles should be available for use as needed to prevent eye contact. Under normal manufacturing conditions, no respiratory protection is required when using this product. Self-contained breathing apparatus (SCBA) is required if a large release occurs.

(EXPOSURE CONTROLS/PERSONAL PROTECTION - Continued)

Exposure Guidelines

Applicable Exposure Limits

PENTAFLUOROETHANE (HFC-125)

PEL (OSHA) : None Established
 TLV (ACGIH) : None Established
 AEL * (DuPont) : 1000 ppm, 8 & 12 Hr. TWA
 WEEL (AIHA) : 1000 ppm, 4900 mg/m³, 8 Hr. TWA

ETHANE, 1,1,1-TRIFLUORO- (HFC-143a)

PEL (OSHA) : None Established
 TLV (ACGIH) : None Established
 AEL * (DuPont) : 1000 ppm, 8 & 12 Hr. TWA
 WEEL (AIHA) : 1000 ppm, 8 Hr. TWA

ETHANE, 1,1,1,2-TETRAFLUORO- (HFC-134a)

PEL (OSHA) : None Established
 TLV (ACGIH) : None Established
 AEL * (DuPont) : 1000 ppm, 8 & 12 Hr. TWA
 WEEL (AIHA) : 1000 ppm, 8 Hr. TWA

* AEL is DuPont's Acceptable Exposure Limit. Where governmentally imposed occupational exposure limits which are lower than the AEL are in effect, such limits shall take precedence.

PHYSICAL AND CHEMICAL PROPERTIES

Physical Data

Boiling Point : -46.7 C (-52.1 F) Average
 Vapor Pressure : 182.1 psia at 25 deg C (77 deg F)
 % Volatiles : 100 WT%
 Evaporation Rate : (CL4 = 1)
 Greater than 1
 Solubility in Water : Not determined
 Odor : Slight ethereal
 Form : Liquefied gas
 Color : Clear, colorless
 Specific Gravity : 1.05 @ 25C (77F)

STABILITY AND REACTIVITY

Chemical Stability

Material is stable. However, avoid open flames and high temperatures.

Incompatibility with Other Materials

Incompatible with active metals, alkali or alkaline earth metals--powdered Al, Zn, Be, etc.

(STABILITY AND REACTIVITY - Continued)

Decomposition

Decomposition products are hazardous. This material can be decomposed by high temperatures (open flames, glowing metal surfaces, etc.) forming hydrofluoric acid and possibly carbonyl fluoride.

These materials are toxic and irritating. Contact should be avoided.

Polymerization

Polymerization will not occur.

TOXICOLOGICAL INFORMATION

Animal Data

The blend is untested.

HFC-125

Inhalation 4 hour ALC: > 709,000 ppm in rats

Single, high inhalation exposures caused lethargy, decreased activity, labored breathing and weight loss. Weak cardiac sensitization effect, a potentially fatal disturbance of heart rhythm caused by a heightened sensitivity to the action of epinephrine. Lowest-Observed-Adverse-Effect-Level for cardiac sensitization: 100,000 ppm. Repeated exposure caused: No significant toxicological effects. No-Observed-Adverse-Effect-Level(NOAEL): 50,000 ppm

No animal data are available to define carcinogenic, developmental or reproductive hazards. In animal testing this material has not caused developmental toxicity. HFC-125 does not produce genetic damage in bacterial or mammalian cell cultures or when tested in animals (not tested for heritable genetic damage).

HFC-134a

Inhalation 4-hour LC50: 567,000 ppm in rats

Single exposure caused: Cardiac sensitization, a potentially fatal disturbance of heart rhythm associated with a heightened sensitivity to the action of epinephrine. Lowest-Observed-Adverse-Effect-Level for cardiac sensitization: 75,000 ppm. Single exposure caused: Lethargy. Narcosis. Increased respiratory rates. These effects were temporary. Single exposure to near lethal doses caused: Pulmonary edema. Repeated exposure caused: Increased adrenals, liver, spleen weight. Decreased uterine, prostate

(TOXICOLOGICAL INFORMATION - Continued)

weight. Repeated dosing of higher concentrations caused: the following temporary effects - Tremors. Incoordination.

CARCINOGENIC, DEVELOPMENTAL, REPRODUCTIVE, MUTAGENIC EFFECTS:

In a two-year inhalation study, HFC-134a, at a concentration of 50,000 ppm, produced an increase in late-occurring benign testicular tumors, testicular hyperplasia and testicular weight. The no-effect-level for this study was 10,000 ppm. Animal data show slight fetotoxicity but only at exposure levels producing other toxic effects in the adult animal. Reproductive data on male mice show: No change in reproductive performance. Tests have shown that this material does not cause genetic damage in bacterial or mammalian cell cultures, or in animals. In animal testing, this material has not caused permanent genetic damage in reproductive cells of mammals (has not produced heritable genetic damage).

HFC-143a

Inhalation 4-hour LC50: >540,000 ppm in rats

Single exposures by inhalation to 500,000 ppm caused anesthesia but no mortality at 540,000 ppm. Cardiac sensitization occurred in dogs at 300,000 ppm following an intravenous challenge with epinephrine. Two, 4-week inhalation have been conducted. In the first study, pathological changes in the testes were observed at all exposure concentrations; no effects were observed in females. The testicular effect was considered related to the method used to expose the rats to HFC-143a. In the second study using the same exposure concentrations, no effects were noted in males at any concentration. Data from a 90-day study revealed no effects in male or female rats at exposures up to 40,000 ppm. Long-term exposure caused significantly decreased body weights in male rats fed 300 mg/kg for 52 weeks, but there was no effect on mortality. Tests in rats demonstrated no carcinogenic activity when administered orally 300 mg/kg/day for 52 weeks and observed for an additional 73 weeks. Tests in bacterial cell cultures demonstrated mutagenic activity, but the compound did not induce transformation of mammalian cells in culture or in the whole animal. Tests in animals demonstrate no developmental toxicity.

ECOLOGICAL INFORMATION

Ecotoxicological Information

Aquatic Toxicity

HFC 143a
96-hour LC50, Rainbow trout: >40 mg/L

HFC-134a
48-hour EC50, Daphnia magna: 980 mg/L
96-hour LC50, Rainbow trout: 450 mg/L

DISPOSAL CONSIDERATIONS

Waste Disposal

Comply with Federal, State, and local regulations. Reclaim by distillation or remove to a permitted waste disposal facility.

TRANSPORTATION INFORMATION

Shipping Information

DOT/IMO/IATA
Proper Shipping Name : Refrigerant Gas R-404A
Hazard Class : 2.2
UN No. : 3337
Label(s) : Nonflammable Gas

Shipping Containers

Tank Cars.

Cylinders
Ton Tanks-----
REGULATORY INFORMATION

U.S. Federal Regulations

TSCA Inventory Status : Reported/Included.

TITLE III HAZARD CLASSIFICATIONS SECTIONS 311, 312

Acute : No
Chronic : No
Fire : No
Reactivity : No
Pressure : Yes

(REGULATORY INFORMATION - Continued)

LISTS:

SARA Extremely Hazardous Substance	-No
CERCLA Hazardous Material	-No
SARA Toxic Chemicals	-No

OTHER INFORMATION

NFPA, NPCA-HMIS

NPCA-HMIS Rating	
Health	: 1
Flammability	: 0
Reactivity	: 1

Personal Protection rating to be supplied by user depending on use conditions.

The data in this Material Safety Data Sheet relates only to the specific material designated herein and does not relate to use in combination with any other material or in any process.

Responsibility for MSDS	: MSDS Coordinator
>	: DuPont Fluoroproducts
Address	: Wilmington, DE 19898
Telephone	: (800) 441-7515

Indicates updated section.

This information is based upon technical information believed to be reliable. It is subject to revision as additional knowledge and experience is gained.

End of MSDS

Material Safety Data Sheet

Genetron[®] AZ-50 (R-507)

1. CHEMICAL PRODUCT AND COMPANY IDENTIFICATION

PRODUCT NAME: Genetron[®] AZ-50 (R-507)
OTHER/GENERIC NAMES: R-125, HFC-125
PRODUCT USE: Refrigerant
MANUFACTURER: Honeywell
101 Columbia Road
Box 1053
Morristown, New Jersey 07962-1053

FOR MORE INFORMATION CALL:
(Monday-Friday, 9:00am-5:00pm)
1-800-522-8001

IN CASE OF EMERGENCY CALL:
(24 Hours/Day, 7 Days/Week)
1-800-707-4555 or Chemtrec 1-800-424-9300

2. COMPOSITION/INFORMATION ON INGREDIENTS

<u>INGREDIENT NAME</u>	<u>CAS NUMBER</u>	<u>WEIGHT %</u>
Pentafluoroethane	354-33-6	50
1,1,1-Trifluoroethane	420-46-2	50

Trace impurities and additional material names not listed above may also appear in Section 15 toward the end of the MSDS. These materials may be listed for local "Right-To-Know" compliance and for other reasons.

3. HAZARDS IDENTIFICATION

EMERGENCY OVERVIEW: Colorless, volatile liquid with ethereal and faint sweetish odor. Non-flammable material. Overexposure may cause dizziness and loss of concentration. At higher levels, CNS depression and cardiac arrhythmia may result from exposure. Vapors displace air and can cause asphyxiation in confined spaces. At higher temperatures, (>250°C), decomposition products may include Hydrofluoric Acid (HF) and carbonyl halides

POTENTIAL HEALTH HAZARDS

SKIN: Irritation would result from a defatting action on tissue. Liquid contact could cause frostbite.

EYES: Liquid contact can cause severe irritation and frostbite. Mist may irritate.

INHALATION: Genetron AZ-50 (R-507) is low in acute toxicity in animals. When oxygen levels in air are reduced to 12-14% by displacement, symptoms of asphyxiation, loss of coordination, increased pulse rate and deeper respiration will occur. At high levels, cardiac arrhythmia may occur.

INGESTION: Ingestion is unlikely because of the low boiling point of the material. Should it occur, discomfort in the gastrointestinal tract from rapid evaporation of the material and consequent evolution of gas would result. Some effects of inhalation and skin exposure would be expected.

MATERIAL SAFETY DATA SHEET

Genetron[®] AZ-50 (R-507)

DELAYED EFFECTS: None known

Ingredients found on one of the OSHA designated carcinogen lists are listed below.

<u>INGREDIENT NAME</u>	<u>NTP STATUS</u>	<u>IARC STATUS</u>	<u>OSHA LIST</u>
No ingredients listed in this section			

4. FIRST AID MEASURES

SKIN: Promptly flush skin with water until all chemical is removed. If there is evidence of frostbite, bathe (do not rub) with lukewarm (not hot) water. If water is not available, cover with a clean, soft cloth or similar covering. Get medical attention if symptoms persist.

EYES: Immediately flush eyes with large amounts of water for at least 15 minutes (in case of frostbite water should be lukewarm, not hot) lifting eyelids occasionally to facilitate irrigation. Get medical attention if symptoms persist.

INHALATION: Immediately remove to fresh air. If breathing has stopped, give artificial respiration. Use oxygen as required, provided a qualified operator is available. Get medical attention. Do not give epinephrine (adrenaline).

INGESTION: Ingestion is unlikely because of the physical properties and is not expected to be hazardous. Do not induce vomiting unless instructed to do so by a physician.

ADVICE TO PHYSICIAN: Because of the possible disturbances of cardiac rhythm, catecholamine drugs, such as epinephrine, should be used with special caution and only in situations of emergency life support. Treatment of overexposure should be directed at the control of symptoms and the clinical conditions.

5. FIRE FIGHTING MEASURES

FLAMMABLE PROPERTIES

FLASH POINT: Gas, not applicable per DOT regulations

FLASH POINT METHOD: Not applicable

AUTOIGNITION TEMPERATURE: >750°C

UPPER FLAME LIMIT (volume % in air): None by ASTM E681

LOWER FLAME LIMIT (volume % in air): None by ASTM E681

FLAME PROPAGATION RATE (solids): Not applicable

OSHA FLAMMABILITY CLASS: Not applicable

EXTINGUISHING MEDIA:

Use any standard agent – choose the one most appropriate for type of surrounding fire (material itself is not flammable)

UNUSUAL FIRE AND EXPLOSION HAZARDS:

Genetron AZ-50 (R-507) is not flammable at ambient temperatures and atmospheric pressure. However, this material will become combustible when mixed with air under pressure and exposed to strong ignition sources.

Contact with certain reactive metals may result in formation of explosive or exothermic reactions under specific conditions (e.g. very high temperatures and/or appropriate pressures).

MATERIAL SAFETY DATA SHEET

Genetron[®] AZ-50 (R-507)

SPECIAL FIRE FIGHTING PRECAUTIONS/INSTRUCTIONS:

Firefighters should wear self-contained, NIOSH-approved breathing apparatus for protection against possible toxic decomposition products. Proper eye and skin protection should be provided. Use water spray to keep fire-exposed containers cool.

6. ACCIDENTAL RELEASE MEASURES

IN CASE OF SPILL OR OTHER RELEASE:

(Always wear recommended personal protective equipment.)

Evacuate unprotected personnel. Protected personnel should remove ignition sources and shut off leak, if without risk, and provide ventilation. Unprotected personnel should not return until air has been tested and determined safe, including low-lying areas.

Spills and releases may have to be reported to Federal and/or local authorities. See Section 15 regarding reporting requirements.

7. HANDLING AND STORAGE

NORMAL HANDLING:

(Always wear recommended personal protective equipment.)

Avoid breathing vapors and liquid contact with eyes, skin or clothing. Do not puncture or drop cylinders, expose them to open flame or excessive heat. Use authorized cylinders only. Follow standard safety precautions for handling and use of compressed gas cylinders.

Genetron AZ-50 (R-507) should not be mixed with air above atmospheric pressure for leak testing or any other purpose.

STORAGE RECOMMENDATIONS:

Store in a cool, well-ventilated area of low fire risk and out of direct sunlight. Protect cylinder and its fittings from physical damage. Storage in subsurface locations should be avoided. Close valve tightly after use and when empty.

8. EXPOSURE CONTROLS/PERSONAL PROTECTION

ENGINEERING CONTROLS:

Provide local ventilation at filling zones and areas where leakage is probable. Mechanical (general) ventilation may be adequate for other operating and storage areas.

PERSONAL PROTECTIVE EQUIPMENT

SKIN PROTECTION:

Skin contact with refrigerant may cause frostbite. General work clothing and gloves (leather) should provide adequate protection. If prolonged contact with the liquid or gas is anticipated, insulated gloves constructed of PVA, neoprene or butyl rubber should be used. Any contaminated clothing should be promptly removed and washed before reuse.

EYE PROTECTION:

For normal conditions, wear safety glasses. Where there is reasonable probability of liquid contact, wear chemical safety goggles.

MATERIAL SAFETY DATA SHEET

Genetron[®] AZ-50 (R-507)

RESPIRATORY PROTECTION:

None generally required for adequately ventilated work situations. For accidental release or non-ventilated situations, or release into confined space, where the concentration may be above the PEL of 1,000 ppm, use a self-contained, NIOSH - approved breathing apparatus or supplied air respirator. For escape: use the former or a NIOSH-approved gas mask with organic vapor canister.

ADDITIONAL RECOMMENDATIONS:

Where contact with liquid is likely, such as in a spill or leak, impervious boots and clothing should be worn. High dose-level warning signs are recommended for areas of principle exposure. Provide eyewash stations and quick-drench shower facilities at convenient locations. For tank cleaning operations, see OSHA regulations, 29 CFR 1910.132 and 29 CFR 1910.133.

EXPOSURE GUIDELINES

<u>INGREDIENT NAME</u>	<u>ACGIH TLV</u>	<u>OSHA PEL</u>	<u>OTHER LIMIT</u>
Pentafluoroethane	None	None	**1000 ppm TWA (8hr)
1,1,1-Trifluoroethane	None	None	*1000 ppm TWA (8hr)

* = Limit established by Honeywell.

** = Workplace Environmental Exposure Level (AIHA).

*** = Biological Exposure Index (ACGIH).

OTHER EXPOSURE LIMITS FOR POTENTIAL DECOMPOSITION PRODUCTS:

Hydrogen Fluoride: ACGIH TLV: 3 ppm ceiling

9. PHYSICAL AND CHEMICAL PROPERTIES

APPEARANCE: Clear, colorless liquid and vapor

PHYSICAL STATE: Gas at ambient temperatures

MOLECULAR WEIGHT: 98.8

CHEMICAL FORMULA: CHF₂CF₃ and CH₃CF₃

ODOR: Faint ethereal odor

SPECIFIC GRAVITY (water = 1.0): 1.07 @ 21.1°C (70°F)

SOLUBILITY IN WATER (weight %): Unknown

pH: Neutral

BOILING POINT: -46.7°C (-52.0°F)

FREEZING POINT: Not Determined

VAPOR PRESSURE: 153.9 psia @ 70°F

366.8 psia @ 130°F

VAPOR DENSITY (air = 1.0): 3.43

EVAPORATION RATE: >1

COMPARED TO: CCl₄ = 1

% VOLATILES: 100 at 68°F (20°C)

FLASH POINT: Not applicable

(Flash point method and additional flammability data are found in Section 5.)

MATERIAL SAFETY DATA SHEET

Genetron[®] AZ-50 (R-507)

10. STABILITY AND REACTIVITY

NORMALLY STABLE? (CONDITIONS TO AVOID):

The product is stable.

Do not mix with oxygen or air above atmospheric pressure. Any source of high temperature, such as lighted cigarettes, flames, hot spots or welding may yield toxic and/or corrosive decomposition products.

INCOMPATIBILITIES:

(Under specific conditions: e.g. very high temperatures and/or appropriate pressures) – Freshly abraded aluminum surfaces (may cause strong exothermic reaction). Chemically active metals: potassium, calcium, powdered aluminum, magnesium and zinc.

HAZARDOUS DECOMPOSITION PRODUCTS:

Halogens, halogen acids and possibly carbonyl halides.

HAZARDOUS POLYMERIZATION:

Will not occur.

11. TOXICOLOGICAL INFORMATION

IMMEDIATE (ACUTE) EFFECTS:

Pentafluoroethane (R-125)

LC₅₀ : 4 hr. (rat) - > 800,000 ppm

Cardiac Sensitization threshold (dog) 75,000 ppm.

Trifluoroethane (R-143a)

LC₅₀ : 4 hr. (rat) - > 540,000 ppm

Cardiac Sensitization NOEL – >250,000 ppm

DELAYED (SUBCHRONIC AND CHRONIC) EFFECTS:

Pentafluoroethane (R-125)

Teratogenic NOEL (rat and rabbit) - 50,000 ppm

Trifluoroethane (R-143a)

Subchronic inhalation (rat) NOEL - ≥50,000 ppm

Chronic NOEL – 10,000 ppm

Teratogenic NOEL (rat) - 40,000 ppm

Subchronic inhalation (rat) NOEL - 40,000 ppm

OTHER DATA:

Pentafluoroethane (R-125) - Not active in four genetic studies

Trifluoroethane (R-143a) - Not active in two genetic tests.

12. ECOLOGICAL INFORMATION

Degradability (BOD): Genetron AZ-50 (R-507) is a gas at room temperature; therefore, it is unlikely to remain in water.

Octanol Water Partition Coefficient: Log P_{ow} = 1.48 (R-125)

MATERIAL SAFETY DATA SHEET

Genetron[®] AZ-50 (R-507)

13. DISPOSAL CONSIDERATIONS

RCRA

Is the unused product a RCRA hazardous waste if discarded? Not a hazardous waste
If yes, the RCRA ID number is: Not applicable

OTHER DISPOSAL CONSIDERATIONS:

Disposal must comply with federal, state, and local disposal or discharge laws. Genetron AZ-50 (R-507) is subject to U.S. Environmental Protection Agency Clean Air Act Regulations Section 608 in 40 CFR Part 82 regarding refrigerant recycling.

The information offered here is for the product as shipped. Use and/or alterations to the product such as mixing with other materials may significantly change the characteristics of the material and alter the RCRA classification and the proper disposal method.

14. TRANSPORT INFORMATION

US DOT HAZARD CLASS: US DOT PROPER SHIPPING NAME: Liquefied gas, n.o.s. (Pentafluoroethane, 1,1,1-Trifluoroethane)
US DOT HAZARD CLASS: 2.2
US DOT PACKING GROUP: Not applicable

US DOT ID NUMBER: UN3163

For additional information on shipping regulations affecting this material, contact the information number found in Section 1.

15. REGULATORY INFORMATION

TOXIC SUBSTANCES CONTROL ACT (TSCA)

TSCA INVENTORY STATUS: Components listed on the TSCA inventory

OTHER TSCA ISSUES: None

SARA TITLE III/CERCLA

"Reportable Quantities" (RQs) and/or "Threshold Planning Quantities" (TPQs) exist for the following ingredients.

INGREDIENT NAME

No ingredients listed in this section

SARA/CERCLA RQ (lb.)

SARA EHS TPQ (lb.)

Spills or releases resulting in the loss of any ingredient at or above its RQ requires immediate notification to the National Response Center [(800) 424-8802] and to your Local Emergency Planning Committee.

SECTION 311 HAZARD CLASS: IMMEDIATE
PRESSURE

MATERIAL SAFETY DATA SHEET

Genetron[®] AZ-50 (R-507)

SARA 313 TOXIC CHEMICALS:

The following ingredients are SARA 313 "Toxic Chemicals". CAS numbers and weight percents are found in Section 2.

INGREDIENT NAME

COMMENT

No ingredients listed in this section

STATE RIGHT-TO-KNOW

In addition to the ingredients found in Section 2, the following are listed for state right-to-know purposes.

INGREDIENT NAME

WEIGHT % COMMENT

No ingredients listed in this section

ADDITIONAL REGULATORY INFORMATION:

Genetron AZ-50 (R-507) is subject to U.S. Environmental Protection Agency Clean Air Act Regulations at 40 CFR Part 82.

WARNING: Contains pentafluoroethane (HFC-125) and trifluoroethane (HFC-143a), greenhouse gases which may contribute to global warming

Do Not vent to the atmosphere. To comply with provisions of the U.S. Clean Air Act, any residual must be recovered.

WHMIS CLASSIFICATION (CANADA):

This product has been evaluated in accordance with the hazard criteria of the CPR and the MSDS contains all the information required by the CPR.

FOREIGN INVENTORY STATUS:

EU – EINECS #: HFC-125 2065578
HFC-143a 2069965

16. OTHER INFORMATION

CURRENT ISSUE DATE: February, 2003

PREVIOUS ISSUE DATE: January, 2000

CHANGES TO MSDS FROM PREVIOUS ISSUE DATE ARE DUE TO THE FOLLOWING:

Section 1: Updated contact information

OTHER INFORMATION: HMIS Classification: Health – 1, Flammability – 1, Reactivity – 0
NFPA Classification: Health – 2, Flammability – 1, Reactivity – 0
ANSI/ASHRAE 34 Safety Group – A1

Regulatory Standards:

1. OSHA regulations for compressed gases: 29 CFR 1910.101
2. DOT classification per 49 CFR 172.101

Toxicity information per PAFT Testing



The MSDS format adheres to the standards and regulatory requirements of the United States and may not meet regulatory requirements in other countries.

DuPont
Material Safety Data Sheet

Page 1

6087FR "SUVA" 95 (R-508B)
Revised 10-JUL-1997

CHEMICAL PRODUCT/COMPANY IDENTIFICATION

Material Identification

Corporate MSDS Number : DU008080

Company Identification

MANUFACTURER/DISTRIBUTOR

DuPont
Fluoroproducts
1007 Market Street
Wilmington, DE 19898

PHONE NUMBERS

Product Information : 1-800-441-7515 (outside the U.S.
302-774-1000)
Transport Emergency : CHEMTREC 1-800-424-9300(outside U.S.
703-527-3887)
Medical Emergency : 1-800-441-3637 (outside the U.S.
302-774-1000)

COMPOSITION/INFORMATION ON INGREDIENTS

Components

Material	CAS Number	%
TRIFLUOROMETHANE	75-46-7	30-50
HEXAFLUOROETHANE	76-16-4	50-70

HAZARDS IDENTIFICATION

Potential Health Effects

Inhalation of high concentrations of vapor is harmful and may cause heart irregularities, unconsciousness, or death. Intentional misuse can be fatal. Vapor reduces oxygen available for breathing and is heavier than air. Liquid contact can cause frostbite.

HUMAN HEALTH EFFECTS:

Human health effects of overexposure by inhalation may include nonspecific discomfort such as nausea, headache, or weakness; temporary nervous system depression with anaesthetic effects such as dizziness, headache, confusion, incoordination, and loss of consciousness; or with gross overexposure, possibly temporary alteration of the heart's electrical activity with irregular pulse, palpitations, or

(HAZARDS IDENTIFICATION - Continued)

inadequate circulation. Individuals with preexisting diseases of the central nervous or cardiovascular system may have increased susceptibility to the toxicity of excessive exposures. Eye or skin contact with the liquid may cause frostbite.

Carcinogenicity Information

None of the components present in this material at concentrations equal to or greater than 0.1% are listed by IARC, NTP, OSHA or ACGIH as a carcinogen.

FIRST AID MEASURES

First Aid

IF HIGH CONCENTRATIONS ARE INHALED: Immediately remove to fresh air. Keep persons calm. Call a physician. If not breathing, give artificial respiration. If breathing is difficult, give oxygen.

IN CASE OF SKIN CONTACT: Flush with water. Treat for frostbite if necessary.

IN CASE OF EYE CONTACT: Flush with water. Call a physician if frostbite occurs.

IF SWALLOWED: Ingestion is not considered a potential route of exposure.

Notes to Physicians

Because of possible disturbances of cardiac rhythm, catecholamine drugs, such as epinephrine, should be considered only as a last resort in life-threatening emergencies.

FIRE FIGHTING MEASURES

Flammable Properties

Flash Point : Will not burn
Flammable limits in Air, % by Volume
LEL : Not applicable.
UEL : Not applicable.

(FIRE FIGHTING MEASURES - Continued)

Fire and Explosion Hazards:

Use water spray or fog to cool containers. Cylinders are equipped with temperature and pressure relief devices but may still rupture under fire conditions. Decomposition may occur, producing HF, CO and possibly COF₂.

Extinguishing Media

Use media appropriate for surrounding material.

Fire Fighting Instructions

Self-contained breathing apparatus (SCBA) is required if cylinders rupture or release under fire conditions. Water runoff should be contained and neutralized prior to release.

ACCIDENTAL RELEASE MEASURES

Safeguards (Personnel)

NOTE: Review FIRE FIGHTING MEASURES and HANDLING (PERSONNEL) sections before proceeding with clean-up. Use appropriate PERSONAL PROTECTIVE EQUIPMENT during clean-up.

Accidental Release Measures

Material evaporates at atmospheric pressure (vaporizes). Ventilate area - especially low places where heavy vapors might collect. Remove open flames.

HANDLING AND STORAGE

Handling (Personnel)

Avoid contact of liquid with eyes and prolonged skin exposure. Use with sufficient ventilation to keep employee exposure below recommended limits.

Storage

Clean, dry area. Do not heat above 51.7 deg. C (125 deg. F)

EXPOSURE CONTROLS/PERSONAL PROTECTION

Engineering Controls

Normal ventilation for standard manufacturing procedures is generally adequate. Local exhaust should be used when large amounts are released. Mechanical ventilation should be used in low places.

Personal Protective Equipment

Neoprene rubber or leather gloves should be used when handling liquid. Chemical splash goggles should be worn when handling liquid. Under normal manufacturing conditions, no respiratory protection is required when using this product. Self-contained breathing apparatus (SCBA) is required if a large spill or release occurs.

Exposure Guidelines

Applicable Exposure Limits

TRIFLUOROMETHANE

PEL (OSHA) : None Established
TLV (ACGIH) : None Established
AEL * (DuPont) : 1000 ppm, 8 & 12 Hr. TWA

HEXAFLUOROETHANE

PEL (OSHA) : None Established
TLV (ACGIH) : None Established
AEL * (DuPont) : 1000 ppm, 8 & 12 Hr. TWA

* AEL is DuPont's Acceptable Exposure Limit. Where governmentally imposed occupational exposure limits which are lower than the AEL are in effect, such limits shall take precedence.

PHYSICAL AND CHEMICAL PROPERTIES

Physical Data

Boiling Point : -88 C (-126 F)
Vapor Density : (Air = 1)
% Volatiles : 100 WT%
Odor : Slight ethereal
Form : Compressed Gas
Color : Clear, colorless

STABILITY AND REACTIVITY

Chemical Stability

Material is stable. However, avoid open flames and high temperatures.

Decomposition

This product can be decomposed by high temperatures (open flames, glowing metal surfaces, etc.) forming HF, COF₂ or CO. These materials are toxic and irritating. Contact should be avoided.

Polymerization

Polymerization will not occur.

TOXICOLOGICAL INFORMATION

Animal Data

TRIFLUOROMETHANE:

Inhalation 4-hr LC50 : >663,000 ppm in rats

Material is untested for skin and eye irritancy, and for animal sensitization.

Effects from single high inhalation exposure to Trifluoromethane include anaesthetic effects, and nonspecific effects such as weight loss were observed at concentrations >22%. No cardiac sensitization was observed in dogs after breathing 800,000 ppm for periods of 5-10 minutes following epinephrine challenge. In another test, dogs exposed to up to 30% or up to 50% (with additional oxygen), had no positive responses. No cardiac sensitization occurred in baboons exposed by inhalation to 10%, 30%, 50%, or 70% Trifluoromethane before or after an epinephrine challenge; there was a dose-related decrease in heart rates and differences in respiratory rates during exposure.

No animal tests are available to define the carcinogenic hazards of Trifluoromethane. The maternal and developmental NOAEL was 50,000 ppm. Trifluoromethane is not considered a unique developmental hazard to the conceptus. There were no developmental or reproductive effects.

Tests have shown that Trifluoromethane does not produce genetic damage in bacterial or mammalian cell cultures. It has not produced genetic damage in tests on animals.

HEXAFLUOROETHANE:

(TOXICOLOGICAL INFORMATION - Continued)

Inhalation 4-hour LC50: >800,000 ppm in rats

Effects observed in animals by inhalation include decreased growth rate, pulmonary changes, irregular respiration, increased urine volume and creatinine, reversible pathological changes in the kidneys, and increased urinary fluoride concentration. One study showed no arrhythmogenic effects in dogs at a concentration of 20%, while another study did show some arrhythmogenic effects in both guinea pigs and dogs. Long-term inhalation exposures resulted in an initial decrease in growth rate, but no other adverse changes were noted. No animal test reports are available to define carcinogenic, developmental, or reproductive hazards. The compound does not produce genetic damage in bacterial cell cultures but has not been tested in animals.

DISPOSAL CONSIDERATIONS

Waste Disposal

Reclaim by distillation or remove to a permitted waste disposal facility. Dispose in accordance with all Federal, State and local regulations.

TRANSPORTATION INFORMATION

Shipping Information

DOT/IMO
Proper Shipping Name : COMPRESSED GAS, N.O.S.
(FLUORINATED HYDROCARBONS)
Hazard Class : 2.2
UN No. : 1956
DOT/IMO Label : Nonflammable Gas

Shipping Containers

Cylinders and ton tanks.

REGULATORY INFORMATION

U.S. Federal Regulations

TSCA Inventory Status : Reported/Included.

TITLE III HAZARD CLASSIFICATIONS SECTIONS 311, 312

Acute : Yes
Chronic : No
Fire : No
Reactivity : No

(REGULATORY INFORMATION - Continued)

Pressure : Yes

LISTS:

SARA Extremely Hazardous Substance - No
CERCLA Hazardous Substance - No
SARA Toxic Chemicals - No

OTHER INFORMATION

NFPA, NPCA-HMIS

NPCA-HMIS Rating
Health : 1
Flammability : 0
Reactivity : 1

Personal Protection rating to be supplied by user depending on use conditions.

The data in this Material Safety Data Sheet relates only to the specific material designated herein and does not relate to use in combination with any other material or in any process.

Responsibility for MSDS : MSDS Coordinator
> : DuPont Fluoroproducts
Address : Wilmington, DE 19898
Telephone : (800) 441-7515

Indicates updated section.

This information is based upon technical information believed to be reliable. It is subject to revision as additional knowledge and experience is gained.

End of MSDS